

2/2-way Angle-Seat Valve with weld end connection, DN 15-65



- High flow rate and long life cycle
- For hygienic connections with weld end bodies
- NC and NO universal actuators with modular universal accessory program up to control heads

Type 2000 can be combined with...



Type 8691

Control head



Type 8690

Pneum. control unit with feedback



Type 1062

Electrical position feedback

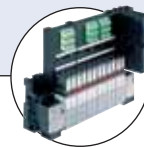

Type 8640/8644

Valve block



Type 6012/6014 P

Pilot valve



Type 2031

Diaphragm valve

The externally piloted angle-seat valve is operated with a single or double-acting piston actuator. The actuator is available in two different materials, PA and PPS depending on the ambient temperature. The reliable self-adjusting packing gland provides high sealing integrity. High flow rates are attained with the stainless steel 2-way body.

These maintenance-free and robust valves can be retrofitted with a comprehensive range of accessories for position indication, stroke limitation or manual override.

For valves with port connection Clamp and threaded port please see separate datasheets.

¹⁾**Note:** For PA actuators in the sizes 50 and 63, the combination of max. medium temperature and max. ambient temperature is as shown in the following chart

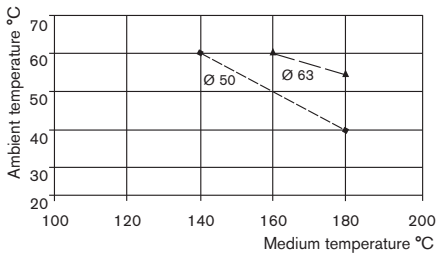

Technical data	
Orifice	DN 15 to 65
Body materials EN ISO 1127/ISO 4200 and DIN 11850 serie 2 ASME BPE and BS 4825 Part 1	Stainless steel 1.4581 (316L on request) Stainless steel 316L
Actuator material	PA (PPS on request)
Seal material	PTFE (NBR, FKM, EPDM on request)
Medium	Water, alcohol, oils, fuel, hydraulic fluids, salt solution, alkali solutions, organic solvents, steam
Viscosity	max. 600 mm ² /s
Packing gland (with silicone grease)	PTFE V-rings with spring compensation
Medium temperature¹⁾	-10 to +180 °C with PTFE seal
Ambient temperature PA actuator ¹⁾ PPS actuator ¹⁾ Ø 50-80 PPS actuator ¹⁾ Ø 100-125	-10 to +60 °C +5 to +140 °C +5 to +90 °C
Installation	As required, preferably with actuator in upright position
Control medium	Neutral gases, air
Max. pilot pressure Actuator size Ø 50-80 Actuator size Ø 100 Actuator size Ø 100	PA and PPS 10 bar PA 10 bar PPS 7 bar
Port connection weld end	EN ISO 1127/ISO 4200, DIN 11850 serie 2, ASME BPE, BS 4825 Part 1
Surface finish on request	standard Ra, internal ≤ 3.2 µm Int. Ra ≤ 0.6 µm (external cast surface) electropolished

Content

Valve specifications		System spec. On/Off Classic	Request for quotation
Type 2000 weld		Type 8801-YA/ 8803-YA	Type 8801-YA/ 8803-YA
Technical data & ordering info.	p. 1-7	Ordering info. & technical data	p. 12

Materials Type 2000 weld end

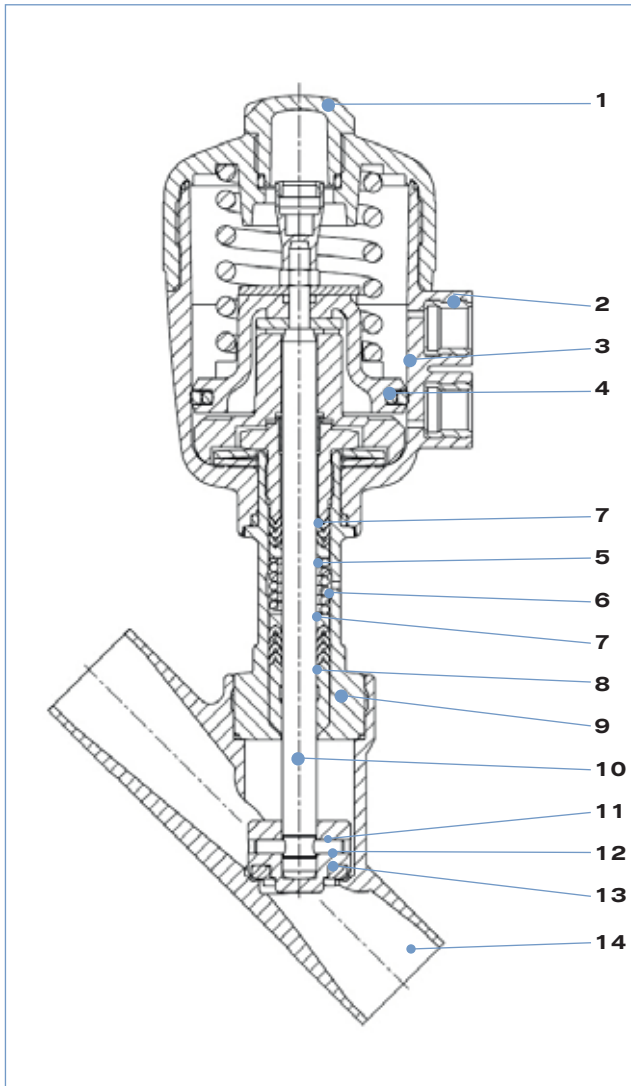

1	Transparent cap	PC (with PPS actuator; PSU)
2	Pilot air ports	Stainless steel 1.4305
3	Actuator	PA (PPS on request)
4	Piston seal	NBR (with PPS actuator; FKM)
5	Spring	Stainless steel 1.4310
6	Tube ²⁾	Stainless steel 1.4401 Stainless steel 316L ³⁾
7	V-Seals	PTFE (FKM on request)
8	Wiper	PTFE PEEK ¹⁾
9	Nipple ²⁾	Stainless steel 1.4401 Stainless steel 316L ³⁾
10	Spindle	Stainless steel 1.4401
11	Pins	Stainless steel 1.4401
12	Swivel plate	Stainless steel 1.4401
13	Seal	PTFE (NBR, FKM, EPDM on request)
14	Valve body	EN ISO 1127/ISO 4200 and DIN 11850 Series 2 Stainless steel 1.4581 (316L on request) ASME BPE/BS 4825 Part 1 Stainless steel 316L

¹⁾ For actuator size 100 mm and 125 mm

²⁾ Single piece with actuator size 63 mm to 125 mm

³⁾ For actuator size 63 mm to 125 mm

Technical data Type 2000 weld end with flow direction below seat (for gas and liquid)

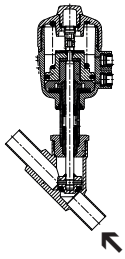

Flow direction below seat

Orifice [mm]	Actuator size [mm]	Kv value water (m ³ /h)	Min. pilot pressure CFA [bar]	Max. operating pressure up to +180°		Weight [kg]
				CFA [bar]	CFB [bar]	
15	50	4.2	3.9	16	16	0.8
20	50	8.0	3.9	11	16	1.0
25	63	19	4.2	11	16	1.8
32	63	27	4.2	6	16	2.3
	80	28	5.0	14	16	3.1
40	63	35	-	-	16	2.7
	80	38	5.0	9	16	3.5
50	63	49	-	-	13	4.0
	100	55	4.4	7.2	-	7.0
65	80	77	-	-	16	6.4
	125	90	3.2	5.2	-	11.0

Kv value water [m³/h]: Measured at +20 °C, 1 bar pressure at valve inlet and free outlet
 Pressure values [bar]: Measured as overpressure to the atmospheric pressure

Pilot pressure diagram with control function B and flow direction below seat

Diagram 1

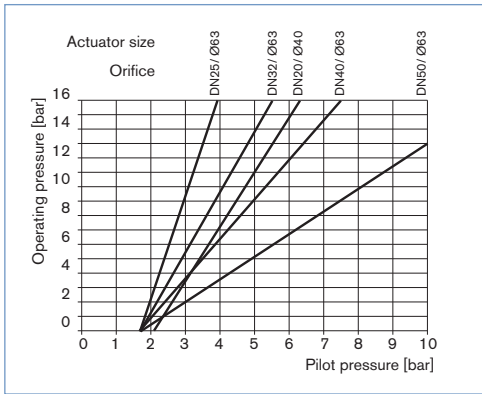
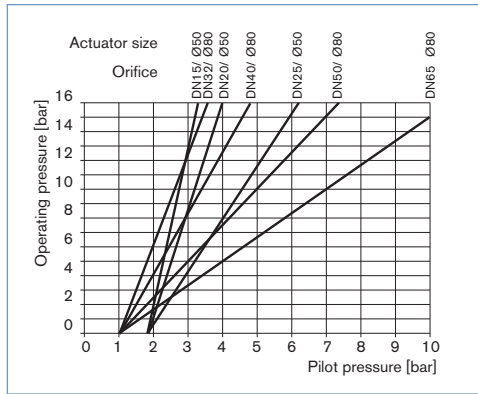

Diagram 2



Ordering chart Type 2000 weld end with flow direction below seat (further versions on request)

Actuator material PA, Ra internal/external ≤ 3.2 µm

Acc. to EN ISO 1127/ISO 4200 and DIN 11850 S2, body in stainless steel 1.4581 (316L on request)

Control function	Orifice [mm]	Actuator size Ø [mm]	Port connection Weld end, tube - Ø [mm]		Min. pilot pressure [bar]	Operating pressure up to 180°C [bar]	Item no.	
			EN ISO 1127/ ISO 4200	DIN 11850 S2			EN ISO 1127/ ISO 4200	DIN 11850 Series 2
A 2/2-way, normally closed (NC) 	15	50	21.3 x 1.6	19 x 1.5	3.9	16	001 392	143 443
	20	50	26.9 x 1.6	23 x 1.5	3.9	11	001 393	143 444
	25	63	33.7 x 2	29 x 1.5	4.2	11	001 394	143 445
	32	80	42.4 x 2	35 x 1.5	5	14	001 395	143 446
	40	80	48.3 x 2	41 x 1.5	5	9	001 396	143 447
	50	100	60.3 x 2.6	53 x 1.5	4.4	7.2	001 397	143 448
B 2/2-way, normally open (NO) 	15	50	21.3 x 1.6	19 x 1.5	see diagram 1 and 2 on previous page	16	001 488	143 449
	20	50	26.9 x 1.6	23 x 1.5		16	001 489	143 450
	25	63	33.7 x 2	29 x 1.5		16	001 490	143 451
	32	63	42.4 x 2	35 x 1.5		16	001 491	143 452
	40	63	48.3 x 2	41 x 1.5		16	001 492	143 453
	50	63	60.3 x 2.6	53 x 1.5		13	001 493	143 454
	65	80	76.1 x 2.3	70 x 2.0		15	168 835	169 989

Acc. to ASME BPE and BS 4825 Part 1, body in stainless steel 316L

Control function	Orifice [mm]	Actuator size Ø [mm]	Port connection Weld end, tube - Ø [mm]		Min. pilot pressure [bar]	Operating pressure up to 180°C [bar]	Item no.	
			ASME BPE	BS 4825 Part 1			ASME BPE	BS 4825 Part 1
A 2/2-way, normally closed (NC) 	15	50	12.7 x 1.65	12.7 x 1.2	3.9	16	154 675	183 271
	20	50	19.05 x 1.65	19.05 x 1.2	3.9	11	183 268	183 273
	25	63	25.4 x 1.65	25.4 x 1.65	4.2	11	154 678	180 507
	40	80	38.1 x 1.65	38.1 x 1.65	5	9	154 680	183 274
	50	100	50.8 x 1.65	50.8 x 1.65	4.4	7.2	183 269	183 275
B 2/2-way, normally open (NO) 	15	50	12.7 x 1.65	12.7 x 1.2	see diagram 1 and 2 on previous page	16	154 676	183 278
	20	50	19.05 x 1.65	19.05 x 1.2		16	164 579	183 279
	25	63	25.4 x 1.65	25.4 x 1.65		16	183 270	183 280
	40	63	38.1 x 1.65	38.1 x 1.65		16	154 681	183 281
	50	63	50.8 x 1.65	50.8 x 1.65		13	174 554	183 282

i Further versions on request

- Material**
Seal: NBR, FKM, EPDM
Actuator: PPS
Body: Stainless steel 316L with port connection acc. to EN ISO 1127/ISO 4200 or DIN 11850 S2
- Control function**
Double-acting actuator
- Port connections**
Clamp, threaded port (see separate datasheets)
- Approvals**
GL, SIL
- Additional**
Surface finish: int. Ra ≤ 0.8 µm electro polished,
int. Ra ≤ 0.4 µm electro polished
- Mediums temperature**
Valves for mediums temperature up to +200°C or down to -40°C

DTS 1000100996 EN Version: N Status: RL (released | freigegeben | valide) printed: 03.06.2014

Technical data Type 2000 weld end with flow direction above seat (only for gas and steam)

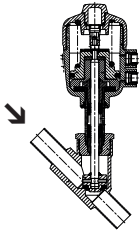

Flow direction above seat

Orifice [mm]	Actuator size [mm]	Kv value water (m ³ /h)	Max. operating pressure up to 180°	Weight [kg]
15	50	4.2	16	0.8
20	50	8.0	16	1.0
25	63	19.0	16	1.8
32	63	27.0	16	2.2
40	63	35.0	16	2.7
50	63	49.0	16	4.0
65	80	77.0	14	6.4

Kv value water [m³/h]: Measured at +20 °C, 1 bar pressure at valve inlet and free outlet
 Pressure values [bar]: Measured as overpressure to the atmospheric pressure

Attention!

Valves with flow direction above the seat are only conditionally usable for liquid medium.
 There is a danger of waterhammer!

Technical data	Flow direction above seat (only for gases and steam)
Medium	Gaseous medium and steam
Further technical data	Please see information Technical data on page 1

Pilot pressure diagram with control function A and flow direction above seat

Diagram 3

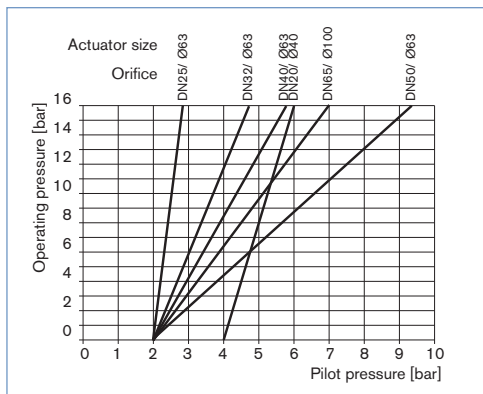
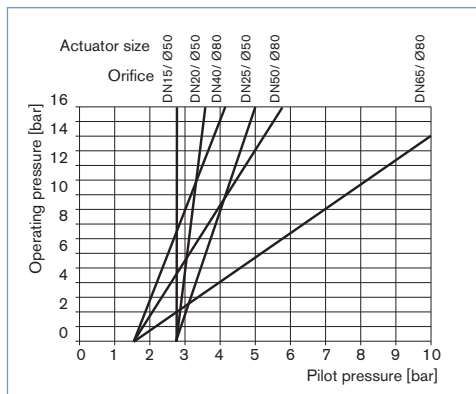

Diagram 4



Ordering chart Type 2000 weld end with flow direction above seat, only for gas & steam
(further versions on request)

Actuator material PA, Ra internal/external ≤ 3.2 µm

Acc. to EN ISO 1127/ISO 4200 and DIN 11850 S2, body in stainless steel 1.4581 (316L on request)

Control function	Orifice [mm]	Actuator size Ø [mm]	Port connection Weld end Tube - Ø [mm]		Min. pilot pressure [bar]	Operating pressure up to +180°C [bar]	Item no.	
			EN ISO 1127/ISO 4200	DIN 11850 Series 2			EN ISO 1127/ISO 4200	DIN 11850 Series 2
A 2/2-way, normally closed (NC) 	15	50	21.3 x 1.6	19 x 1.5	See diagram 3 and 4 above	16	001 449	143 455
	20	50	26.9 x 1.6	23 x 1.5		16	001 448	143 456
	25	63	33.7 x 2	29 x 1.5		16	001 447	143 457
	32	63	42.4 x 2	35 x 1.5		16	001 414	143 458
	40	63	48.3 x 2	41 x 1.5		16	001 415	143 459
	50	63	60.3 x 2.6	53 x 1.5		16	001 416	143 460
	65	80	76.1 x 2.3	70 x 2.0		14	431 530	171 013

Acc. to ASME BPE and BS 4825 Part1, body in stainless steel 316L

Control function	Orifice [mm]	Actuator size Ø [mm]	Port connection Weld end, tube - Ø [mm]		Min. pilot pressure [bar]	Operating pressure up to +180°C [bar]	Item no.	
			ASME BPE	BS 4825 Part 1			ASME BPE	BS 4825 Part 1
A 2/2-way, normally closed (NC) 	15	50	12.7 x 1.65	12.7 x 1.2	See diagram 3 and 4 on previous page	16	183 283	183 290
	20	50	19.05 x 1.65	19.05 x 1.2		16	183 284	183 291
	25	63	25.4 x 1.65	25.4 x 1.65		16	183 286	183 351
	40	63	38.1 x 1.65	38.1 x 1.65		16	183 288	183 353
	50	63	50.8 x 1.65	50.8 x 1.65		16	166 536	183 355

i Further versions on request



Material
 Seal: NBR, FKM, EPDM
 Actuator: PPS
 Body: Stainless steel 316L with port connection acc. to EN ISO 1127/ISO 4200 or DIN 11850 S2



Port connections
 Clamp, threaded port (see separate data-sheets)



Mediums temperature
 Valves for mediums temperature up to +200°C or down to -40°C



Control function
 Double-acting actuator



Approvals
 GL, SIL



Additional
 Surface finish: int. Ra ≤ 0.8 µm electro polished, int. Ra ≤ 0.4 µm electro polished

Ordering chart for accessories

3/2-way pilot valves with banjo bolts

Seal material valve FKM, seal material banjo bolt NBR

Valve for actuator size [Ø mm]	Type	Pressure inlet P (valve body)	Service port A (banjo bolt)	Orifice [mm]	Qn value air [l/min]	Pressure range [bar]	Electrical coil connection Ind. Std.	Power consumption [W]	Item no. Voltage/frequency [V/Hz]
									024/DC 230/50
50-63	6012P	Tube fitting ø6 mm	G 1/4	1.2	48	0-10	Form B	4	552 283 552 286
40	6012P	G 1/4	G 1/8	1.2	48	0-10	Form B	4	552 295 552 298
50-125	6014P	G 1/4	G 1/4	2	120	0-10	Form A	8	424 103 424 107

Cable plug Type 2507, Form B or Type 2508, Form A

	Item no.
Type 2507, Form B Industrial standard, 0 to 250 V without circuitry (Type 6012 P)	423 845
Type 2508, Form A acc. DIN EN 175301-803, 0 to 250 V without circuitry (Type 6014 P, Type 0331P)	008 376

For further accessories see datasheet for Type 1062 or the accessories datasheet Type 2XXX for the full options programme.

Note: For design reasons, some of the accessories cannot be supplied for actuator size Ø 40 mm. Please request the accessories datasheet Type 2XXX.

Dimensions Type 2000 weld end [mm]

Acc. to EN ISO 1127/ISO 4200 and DIN 11850 Series 2

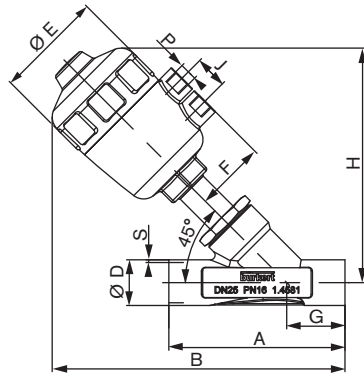

DN	Actuator size Ø	Ø E	F	P	J	B	H	A	G	Weld end body acc. to EN ISO 1127/ISO 4200		Weld end body acc. to DIN 11850 Series 2	
										Ø D	S	Ø D	S
15	50	64	44	G 1/4	24	174	137	100	34	21.3	1.6	19	1.5
20	50	64	44	G 1/4	24	181	145	115	39	26.9	1.6	23	1.5
25	63	80	52	G 1/4	24	217	173	130	43	33.7	2	29	1.5
32	63	80	52	G 1/4	24	230	186	145	45	42.4	2	35	1.5
	80	101	60	G 1/4	24	259	210						
40	63	80	52	G 1/4	24	238	189	160	49	48.3	2	41	1.5
	80	101	60	G 1/4	24	258	213						
50	63	80	52	G 1/4	24	255	205	175	50	60.3	2.6	53	1.5
	100	127	73	G 1/4	30	327	271						
65	80	101	60	G 1/4	24	292	242	210	50	76.1	2.3	70	2.0
	125	158	86	G 1/4	30	370	320						

Acc. to BS 4825 Part 1 and ASME BPE

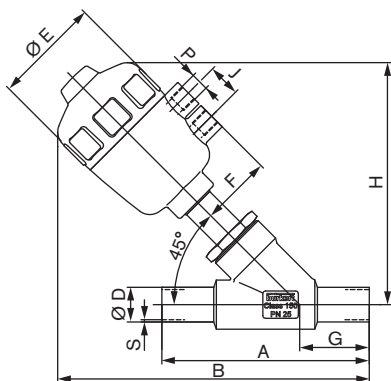

DN	Actuator size Ø	Ø E	H	F	P	J	Weld end body acc. to BS 4825 Part 1					Weld end body acc. to ASME BPE				
							A ¹⁾	B	Ø D	G	S	A ¹⁾	B	Ø D	G	S
15	50	64	145	44	G 1/4	24	135	191	12.7	46	1.2	135	191	12.7	46	1.65
20	50	64	149	44	G 1/4	24	145	201	19.05	52	1.2	145	201	19.05	52	1.65
25	63	80	178	52	G 1/4	24	152	229	25.4	51	1.65	152	229	25.4	51	1.65
40	63	80	191	52	G 1/4	24	182	251	38.1	60	1.65	182	251	38.1	60	1.65
	80	101	213	60	G 1/4	24										
50	63	80	209	52	G 1/4	24	210	273	50.8	64	1.65	210	273	50.8	64	1.65
	100	127	277	73	G 1/4	30										

¹⁾ Long version (Code AF93)

Ordering information for valve system On/Off Classic Type 8801-YA/8803-YA

A valve system On/Off Classic Type 8801-YA/8803-YA consists of an angle-seat valve Type 2000 and a valve actuation system control head Type 8691, a pneumatic control unit Type 8690 or an electrical position feedback Type 1062 (see separate datasheets).

For the configuration of further valve systems please use the "Request for quotation" on p. 12 [go to page](#)

You order two components and receive a complete assembled and certified valve.

Ordering the valve system On/Off Classic Type 8801-YA/8803-YA

**Angle-seat valve
Type 2000 weld end**



Control units



8691



8690



1062

**Angle-seat valve with
desired control unit**

For port connections clamp and threaded port, see separate datasheets



**Valve system
On/Off Classic
Type 8801-YA-H
2000 + 8691**



**Valve system
On/Off Classic
Type 8801-YA-K
2000 + 8690**



**Valve system
On/Off Classic
Type 8803-YA
2000 + 1062**

When you click on the orange box "More info." below, you will come to our website for the resp. product where you can download the datasheet.

Control head Type 8691



More info.

The new generation of integrated control heads for combination with actuators from the process valve series Type 20xx/21xx is specially designed for the requirements of hygienic process environments. The intelligent control head, Type 8691, detects the valve position by means of a contact-free analog position sensor circumventing excessive wear of mechanical parts. Single or double-acting actuators are controlled via the integral pilot valve. Communication interfaces AS-Interface and DeviceNet are available as options.

Main customer benefits:

- Automatic setting of the control head at the push of a button
- Even under dirty or dark environments, a clearly visible status display due to powerful LEDs
- Monitoring and diagnosis: Process valve systems with field bus interface used in modern plant processes
- Integrated pilot valve with manual actuation
- Air intake filter enhances the process valve system availability
- Simple and reliable actuator adaptations allowing additional actuators of the process valve series, Type 20xx or actuators from other manufacturers to be used

**Pneumatic control unit
Type 8690**



More info.

The new generation of integrated controllers for combination with actuators from the process valve series Type 20xx/21xx is specially designed for the requirements of hygienic process environments. The pneumatic control unit Type 8690 combines electrical position feedback and pneumatic control for single or double-acting actuators, and is also optionally available as an intrinsically safe model to ATEX.

Main customer benefits:

- Integrated pilot valve with manual actuation
- Air intake filter enhances the process valve system availability
- Simple and reliable actuator adaptations allowing additional actuators of the process valve series, Type 20xx or actuators from other manufacturers to be used

**Electrical Position Feedback
Type 1062**



More info.

Positions are electrically signaled according to switch type:

- open,
- closed or
- open and closed.

LEDs provide optical position indication (except for Namur Ex-version). Mechanical or inductive switches are housed in a compact splash-proof enclosure. The position indicator can be rotated 360° and is easily fitted to the valve. Trip cams do not require adjustment. The unit only needs to be screwed on and connected to be ready for operation.

Dimensions for valve system On/Off Classic Type 8801-YA-H [mm]

Dimensions valve system On/Off Classic Type 8801-YA-H with TopControl Type 8691 [mm]

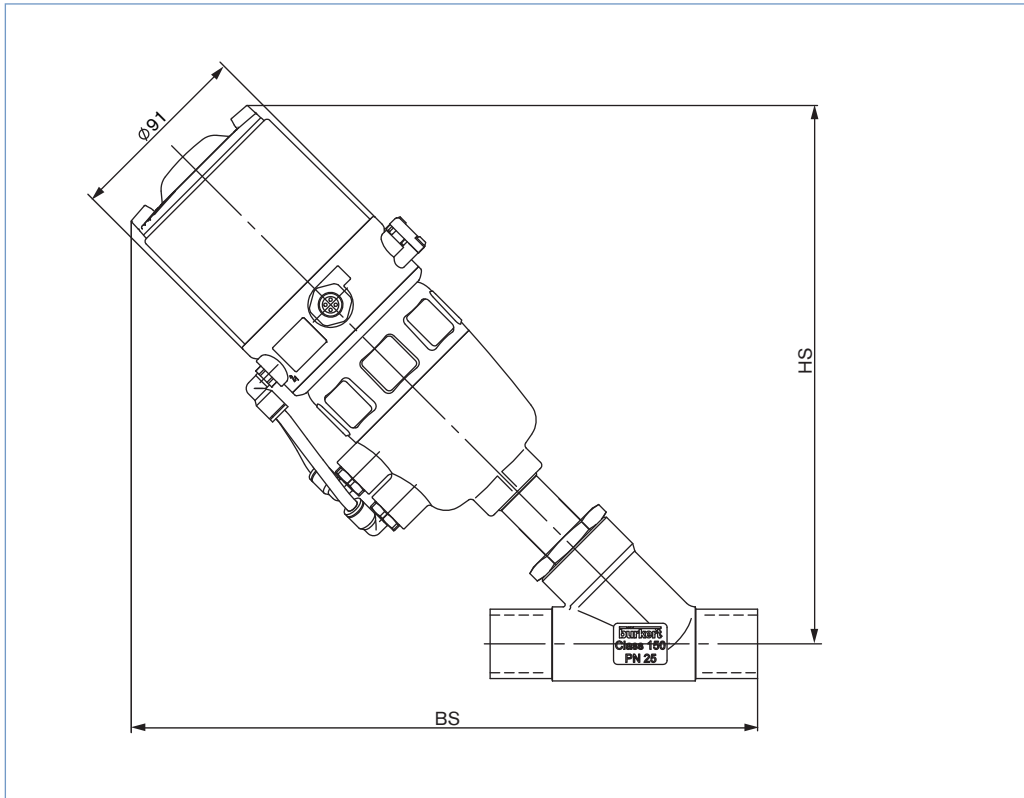

Acc. to EN ISO 1127/ISO 4200, DIN 11850 S2 [mm]

Orifice [mm]	Actuator size [mm]	HS [mm]	BS [mm]
15	50	234	268
20	50	238	277
25	63	263.5	306.5
32	63	273.5	313.5
	80	289.5	329.5
40	63	276.5	325.5
	80	293.5	342.5
50	63	294.5	344.5
	100	351.5	401.5
65	80	322.5	372.5
	125	387.5	437.5

ACC. to ASME BPE, BS 4825, SMS 3008 [mm]

Orifice [mm]	Actuator size [mm]	HS [mm]	BS [mm]
15	50	234	280
20	50	238	290
25	63	263.5	314.5
32	63	273.5	313.5
	80	289.5	329.5
40	63	276.5	336.5
	80	293.5	353.5
50	63	294.5	358.5
	100	351.5	415.5
65	80	322.5	378.5
	125	387.5	443.5

Dimensions for valve system On/Off Classic Type 8801-YA-K [mm]

Dimensions valve system On/Off Classic Type 8801-YA-K with TopControl Type 8690 [mm]

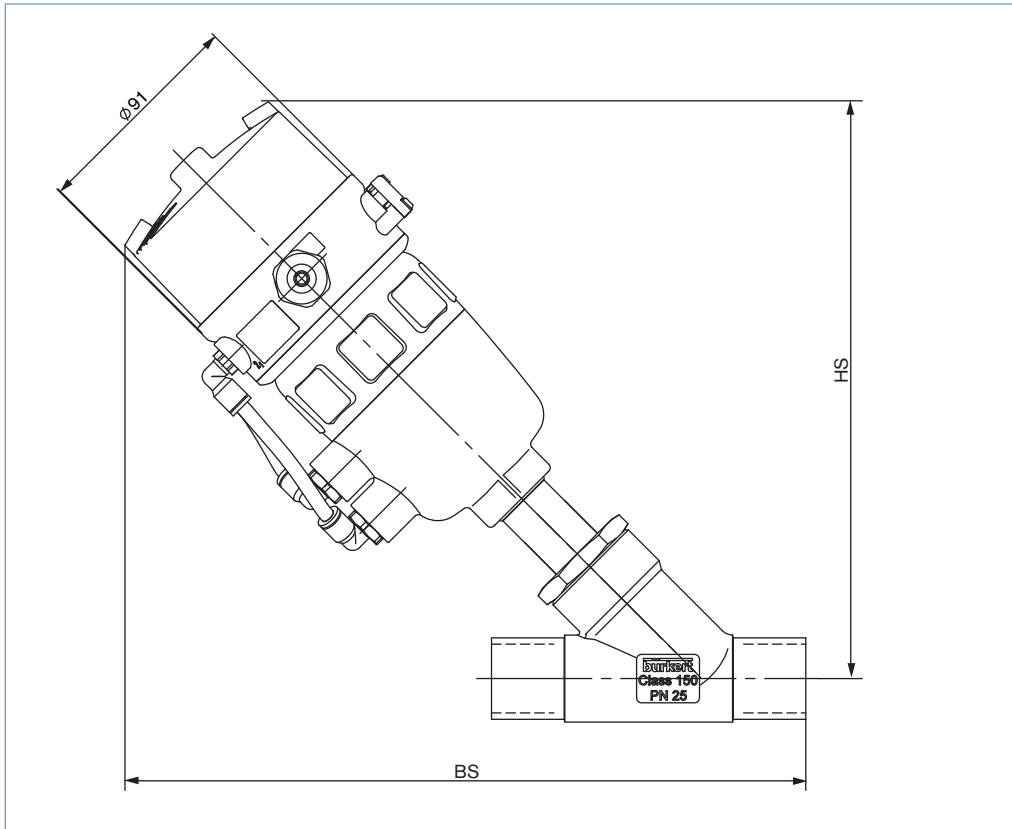

Acc. to EN ISO 1127/ISO 4200, DIN 11850 S2 [mm]

Orifice [mm]	Actuator size [mm]	HS [mm]	BS [mm]
15	50	210	244
20	50	214	253
25	63	239	283
32	63	250	290
	80	265.5	305.5
40	63	253	302
	80	269.5	318.5
50	63	271	321
	100	327.5	377.5
65	80	298.5	348.5
	125	363.5	413.5

Acc. to ASME BPE, BS 4825, SMS 3008 [mm]

Orifice [mm]	Actuator size [mm]	HS [mm]	BS [mm]
15	50	210	256
20	50	214	266
25	63	239	291
32	63	250	290
	80	265.5	305.5
40	63	253	313
	80	269.5	329.5
50	63	271	335
	100	327.5	391.5
65	80	298.5	354.5
	125	363.5	419.5

Dimensions for valve system On/Off Classic Type 8803-YA [mm]

Dimensions valve system On/Off Classic Type 8803-YA with electrical position feedback Type 1062 [mm]

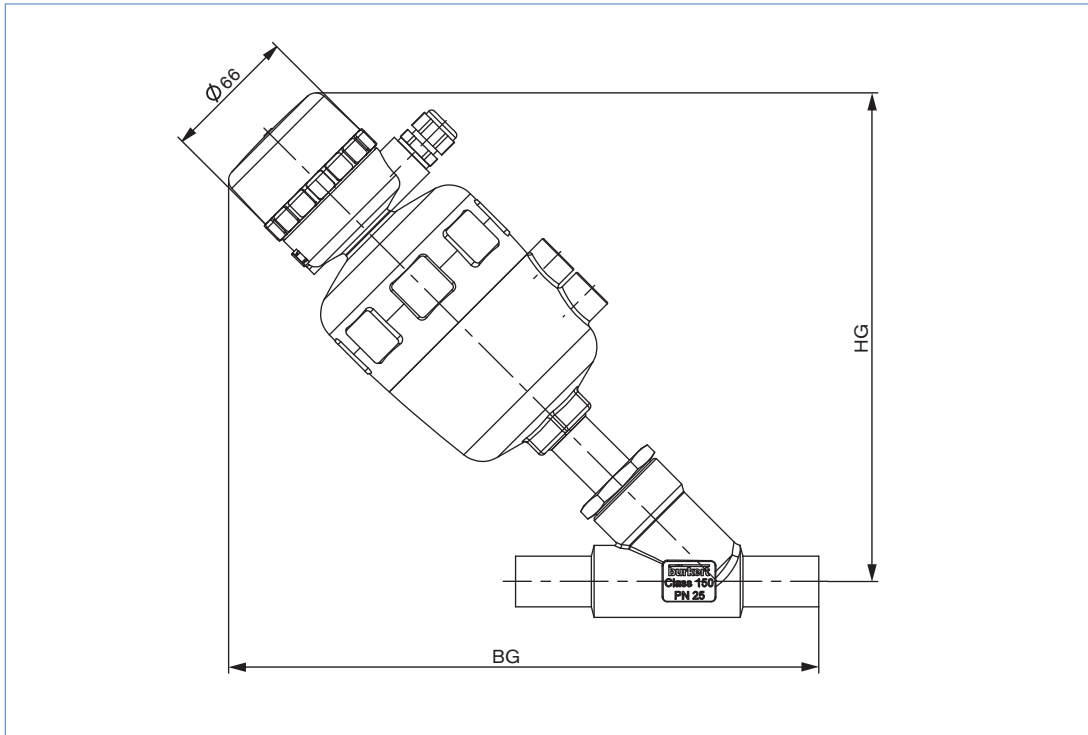

Acc. to EN ISO 1127/ISO 4200 und DIN 11850 S2 [mm]

Orifice [mm]	Actuator size [mm]	HG [mm]	BG [mm]
15	50	192	229
20	50	200	236
25	63	225	269
32	63	238	282
	80	256	305
40	63	241	290
	80	259	304
50	63	257	307
	100	313	369
65	80	288	338
	125	355	405

Acc. to BS 4825 Part 1 und ASME BPE [mm]

Orifice [mm]	Actuator size [mm]	HG [mm]	BG [mm]
15	50	200	246
20	50	204	256
25	63	230	281
40	63	243	303
	80	259	319
50	63	261	325
	100	319	383

Note
You can fill out the fields directly in the PDF file before printing out the form.

Valve system On/Off Classic Type 8801-YA/8803-YA – request for quotation

Please fill out and send to your nearest Bürkert facility* with your inquiry or order

Company	Contact person
Customer no.	Department
Address	Tel./Fax
Postcode/town	E-Mail

= mandatory fields to fill out Quantity Required delivery date

Operating data

Pipeline	DN	<input type="text"/>	PN	<input type="text"/>
Pipe material	<input type="text"/>			
Process medium	<input type="text"/>			
Type of medium	<input type="checkbox"/> Liquid	<input type="checkbox"/> Steam	<input type="checkbox"/> Gas	
	standard	unit		
Flow rate (Q, Q _N , W) ¹⁾	<input type="text"/>	<input type="text"/>		
Temperature at valve inlet	<input type="text"/>	<input type="text"/>		
Absolute pressure at valve inlet	<input type="text"/>	<input type="text"/>		

¹⁾ standard unit: Liquid Q = m³/h; Steam W = kg/h; Gas Q_N = Nm³/h

Valve features

Actuator material	<input type="checkbox"/> PA	<input type="checkbox"/> PPS
Body material	<input type="checkbox"/> Stainless steel	<input type="checkbox"/> Gunmetal
Seat sealing material	<input type="checkbox"/> PTFE <input type="checkbox"/> NBR	<input type="checkbox"/> Other <input type="text"/>
Nominal pressure	PN <input type="text"/>	
Nominal size	DN <input type="text"/>	
Type of connection	<input type="checkbox"/> Welded <input type="checkbox"/> Internal thread <input type="checkbox"/> Clamp	
Standard connection	<input type="checkbox"/> ISO <input type="checkbox"/> DIN <input type="checkbox"/> ANSI <input type="checkbox"/> JIS <input type="checkbox"/> Other <input type="text"/>	
Function	<input type="checkbox"/> NC ²⁾ <input type="checkbox"/> NO ²⁾ <input type="checkbox"/> Double-acting	
Pilot pressure	<input type="text"/> min.	<input type="text"/> max.

²⁾ NC: normally closed by spring action; NO: normally open by spring action

Control unit features

Click on the orange box "More info." below... you will come to our website for the resp. product where you can download the datasheet.

Pneumatic Control Unit	Control Head	Electrical position feedback
<input type="checkbox"/> Type 8691 More info.	<input type="checkbox"/> Type 8690 More info.	<input type="checkbox"/> Type 1062 More info.
Pneumatic function <input type="checkbox"/> Single-acting <input type="checkbox"/> Double-acting Pilot air ports <input type="checkbox"/> Push-in connector external ø 6 mm or 1/4" <input type="checkbox"/> Thread G 1/8" Communication <input type="checkbox"/> ASI <input type="checkbox"/> Multipol M12 <input type="checkbox"/> Flat cable clip, 1 m cable <input type="checkbox"/> DeviceNet Please specify item no. if known: <input type="text"/>	Pneumatic function <input type="checkbox"/> Single-acting <input type="checkbox"/> Double-acting <input type="checkbox"/> Without pilot valve Position feedback <input type="checkbox"/> 1x inductive <input type="checkbox"/> 2x inductive <input type="checkbox"/> 1x inductive (NAMUR) <input type="checkbox"/> 2x inductive (NAMUR) <input type="checkbox"/> 1x mechanical <input type="checkbox"/> 2x mechanical Supply voltage <input type="checkbox"/> 24 V / DC (ATEX Zone 2/22) <input type="checkbox"/> Ex ia IIC T6 (ATEX Zone 1) Pilot air ports <input type="checkbox"/> Push-in connector <input type="checkbox"/> Thread G 1/8" external ø 6 mm or 1/4" Please specify item no. if known: <input type="text"/>	Limit switches <input type="checkbox"/> mechanical <input type="checkbox"/> Voltage 12-48 V <input type="checkbox"/> Voltage 110-250 V <input type="checkbox"/> inductive <input type="checkbox"/> NAMUR EExi Status <input type="checkbox"/> closed <input type="checkbox"/> open <input type="checkbox"/> open/closed Please specify item no. if known: <input type="text"/>

continued on next page →

* To find your nearest Bürkert facility, click on the orange box → www.burkert.com

Valve system On/Off Classic Type 8801-YA/8803-YA – request for quotation, *continued*

Control unit features	
Pilot valve	Stroke limitation
<input type="checkbox"/> Pilot valve	<input type="checkbox"/> Stroke limitation
Power supply <input type="text"/>	<input type="checkbox"/> Min./max. stroke limitation , with visual position indicator
	<input type="checkbox"/> Max. stroke limitation , without visual position indicator
Please specify item no. if known: <input type="text"/>	Please specify item no. if known: <input type="text"/>

Certifications
<input type="checkbox"/> Attestation of compliance with the order EN-ISO 10204 2.1
<input type="checkbox"/> Test report EN-ISO 10204 2.2
<input type="checkbox"/> Certification of Conformity for Raw Material EN-ISO 10204 3.1
<input type="checkbox"/> EN161 (European Gas Device guideline)

Comment / sketch

DTS 1000100996 EN Version: N Status: RL (released | freigegeben | valide) printed: 03.06.2014