

## Bargraph Indicators 48N Series

### BARGRAPH INDICATOR

#### Functions & Features

- Displays two process variables in dual graphic bargraphs of 101 LED segments
- Single and dual bargraphs
- IP65 front cover
- Scale plate is easily replaced
- Separable terminal block

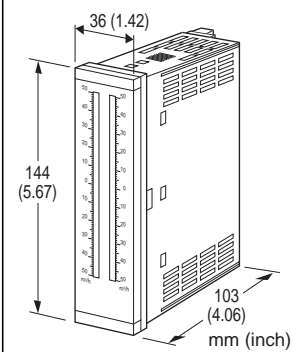

### MODEL: 48NV-[1][2][3][4]-[5][6]

#### ORDERING INFORMATION

- Code number: 48NV-[1][2][3][4]-[5][6]
- Specify a code from below for each [1] through [6]. (e.g. 48NV-2BBV4W-R/CE/D)
- Special input range (For codes Z & 0)
- Bargraph scale (e.g. 0 - 100 %) (See 'Scale Plate.')

#### [1] BARGRAPHS

- 1: Single
- 2: Dual

#### [2] BAR LED COLOR

- R: Red
- Y: Amber
- G: Green
- B: Blue
- Dual (left/right)**
- RR: Red / Red
- YY: Amber / Amber
- GG: Green / Green
- BB: Blue / Blue
- RY: Red / Amber
- RG: Red / Green
- RB: Red / Blue

- YR: Amber / Red
- YG: Amber / Green
- YB: Amber / Blue
- GR: Green / Red
- GY: Green / Amber
- GB: Green / Blue
- BR: Blue / Red
- BY: Blue / Amber
- BG: Blue / Green

#### [3] MOUNTING DIRECTION

- V: Vertical
- H: Horizontal

#### [4] INPUT

##### Current

- A: 4 - 20 mA DC (Input resistance 10 Ω)
- B: 2 - 10 mA DC (Input resistance 20 Ω)
- C: 1 - 5 mA DC (Input resistance 39 Ω)
- D: 0 - 20 mA DC (Input resistance 10 Ω)
- E: 0 - 16 mA DC (Input resistance 12 Ω)
- F: 0 - 10 mA DC (Input resistance 20 Ω)
- G: 0 - 1 mA DC (Input resistance 200 Ω)
- H: 10 - 50 mA DC (Input resistance 5.1 Ω)
- Z: Specify current (See INPUT SPECIFICATIONS)

##### Voltage

- 3: 0 - 1 V DC (Input resistance 1 MΩ min.)
- 4: 0 - 10 V DC (Input resistance 1 MΩ min.)
- 5: 0 - 5 V DC (Input resistance 1 MΩ min.)
- 6: 1 - 5 V DC (Input resistance 1 MΩ min.)
- 4W: -10 - +10 V DC (Input resistance 1 MΩ min.)
- 5W: -5 - +5 V DC (Input resistance 1 MΩ min.)
- 0: Specify voltage (See INPUT SPECIFICATIONS)

#### [5] POWER INPUT

##### AC Power

M: 85 - 264 V AC (Operational voltage range 85 - 264 V, 47 - 66 Hz)

(CE not available)

M2: 100 - 240 V AC (Operational voltage range 85 - 264 V, 47 - 66 Hz)

##### DC Power

R: 24 V DC

(Operational voltage range 24 V ±15 %, ripple 10 %p-p max.)

#### [6] OPTIONS (multiple selections)

##### Standards & Approvals

blank: Without CE

/CE: CE marking

##### Bezels

**blank:** Bezels for M-System's 48 Series panel cutout  
**/D:** Bezels for DIN panel cutout  
**/F:** Bezels for Fuji Electric's PAJ, PAK, PBA panel cutout

## BEZEL OPTION

Bezels are used to adapt the 48N Series to an existing panel cutout. In order to replace M-System's 48 Series products, use the one attached to the 48N Series as standard. When the existing panel is cut according to DIN standard, specify '/D' suffix code.

For a new installation, no bezel is required. Please refer to 'Mounting Requirement' and mount the 48N directly. Ingress protection is invalid when the 48N is mounted with a bezel, or when multiple modules are stacked side by side.

## RELATED PRODUCTS

- Spare scale plate

## GENERAL SPECIFICATIONS

**Construction:** Panel flush mounting  
**Degree of protection:** IP65; applicable to the front panel for single unit mounted according to the specified panel cutout  
**Connection:** M3 screw terminals (torque 0.6 N·m)  
**Screw terminal:** Nickel-plated steel  
**Housing material:** Flame-resistant resin (black)  
**Isolation:** Input 1 to input 2 to power  
**Scale plate:** Flame resistant resin (white scale & characters on black base)

## INPUT SPECIFICATIONS

■ **DC Current:** 0 - 50 mA DC; input resistor incorporated  
**Minimum span:** 1 mA  
When specifying a resistance value, choose from below.  
5.1 Ω, 10 Ω, 12 Ω, 20 Ω, 39 Ω, 200 Ω  
■ **DC Voltage:** 0 - 10 V DC  
**Minimum span:** 0.1 V  
**Input resistance:** ≥ 1 MΩ  
**Offset:** Max. 1.5 times span

## INSTALLATION

**Power Consumption**  
• **AC:**  
Approx. 3 VA (single) or 4 VA (dual)  
• **DC:** Approx. 1.5 W (single) or 2 W (dual)  
**Operating temperature:** -5 to +55°C (23 to 131°F)  
**Operating humidity:** 30 to 90 %RH (non-condensing)  
**Mounting:** Panel flush mounting  
**Weight:** 300 g (0.66 lb)

## PERFORMANCE in percentage of span

**Accuracy:** ±1 % ±1 digit  
**Response time:** ≤ 0.5 sec.  
**Insulation resistance:** ≥ 100 MΩ with 500 V DC  
**Dielectric strength:** 2000 V AC @1 minute (input 1 to input 2 to power to ground)

## STANDARDS & APPROVALS

**CE conformity:**  
EMC Directive (2004/108/EC)  
EMI EN 61000-6-4: 2007  
EMS EN 61000-6-2: 2005  
Low Voltage Directive (2006/95/EC)  
EN 61010-1: 2001  
Installation Category II  
Pollution Degree 2  
Input 1 or input 2 to power input:  
Reinforced insulation (300 V)  
Input 1 to input 2: Functional insulation

## SCALE PLATE

### ■ WHAT MUST BE SPECIFIED WHEN ORDERING

Please specify the bargraph scale range and engineering unit. The overall scale plate design including the number of divisions, division line length, character font is determined by M-System.

[Example] : Bargraph range 0 to 300 cm  
 Bargraph scale range: 0 – 300  
 Engineering unit for the bargraph: cm

### ■ TYPES OF DIVISIONS

Five (5) types of divisions are used depending upon the scale span, which determined by the following equation:

$$\text{Scale Span} = (\text{Max. range value} - \text{Min. range value}) \times 10^n$$

where n = integer (used to limit the calculated scale span to the minimum of 1.1, below 11.0.)

The number of divisions is automatically determined by the scale span.

#### • Type 1: 1.1 Scale Span < 1.3

Number of divisions: 22 to 25.9

Scale: Starts at 0, increments by 0.02 / 0.2 / 2 / 20 / 200. Min. and max. values indicated. 4 digits including negative sign and decimal point.

Division lines: Long, Short, Medium, Short, Long (4 divisions repeated)

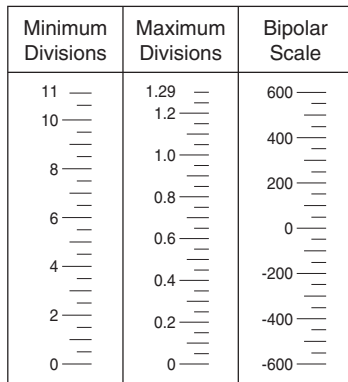

#### • Type 3: 2.0 Scale Span < 2.6

Number of divisions: 40 to 51.9

Scale: Starts at 0, increments by 0.05 / 0.5 / 5 / 50 / 500. Min. and max. values indicated. 4 digits including negative sign and decimal point.

Division lines: Long, Short, Medium, Short, Medium, Short, Medium, Short, Long (10 divisions repeated)

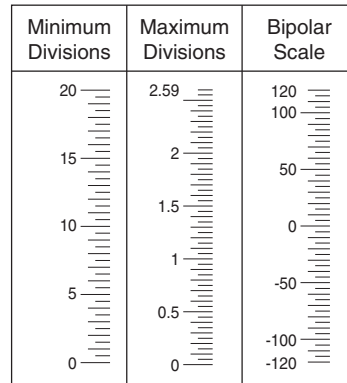

#### • Type 2: 1.3 Scale Span < 2.0

Number of divisions: 26 to 39.9

Scale: Starts at 0, increments by 0.03 / 0.3 / 3 / 30 / 300. Min. and max. values indicated. 4 digits including negative sign and decimal point.

Division lines: Long, Short, Medium, Short, Medium, Short, Long (6 divisions repeated)

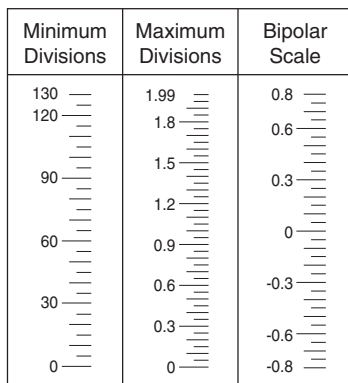

#### • Type 4: 2.6 Scale Span < 5.5

Number of divisions: 26 to 54.9

Scale: Starts at 0, increments by 0.05 / 0.5 / 5 / 50 / 500. Min. and max. values indicated. 4 digits including negative sign and decimal point.

Division lines: Long, Medium, Medium, Medium, Long (5 divisions repeated)

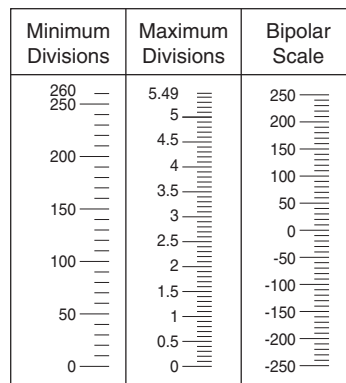

• **Type 5: 5.5 Scale Span < 11.0**

Number of divisions: 27.5 to 54.9

Scale: Starts at 0, increments by 0.01 / 0.1 / 1 / 10 / 100 / 1000. Min. and max. values indicated.

4 digits including negative sign and decimal point.

Division lines: Long, Medium, Medium, Medium, Medium, Long (5 divisions repeated)

[Example] : Bargraph range 0 to 300 cm (Type 4)

Left scale range: 0 – 300

Left scale unit (bargraph): cm

Right scale: None

Minimum Divisions	Maximum Divisions	Bipolar Scale
550	10.9	0.5
500	10	0.4
	9	0.3
400	8	0.2
	7	0.1
300	6	0
	5	-0.1
200	4	-0.2
	3	-0.3
100	2	-0.4
	1	-0.5
0	0	

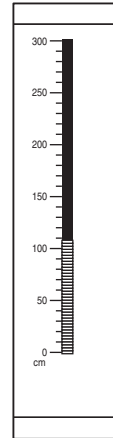

## EXTERNAL VIEW

### ■ VERTICAL MOUNTING

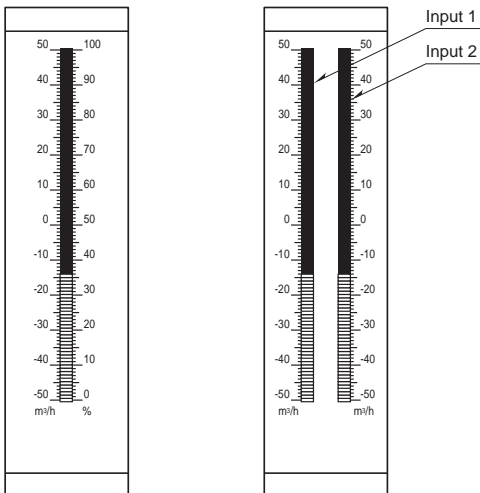

### ■ HORIZONTAL MOUNTING

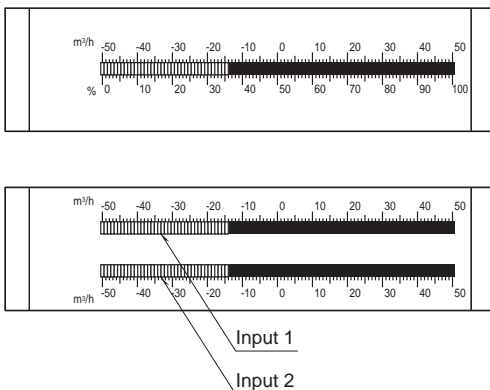

• **Overrange Input**

With an input below 0%, the low-end segment (0%) blinks.

With an input above 100%, all segments are on and the high-end segment (100%) blinks.

## DIMENSIONS unit: mm (inch)

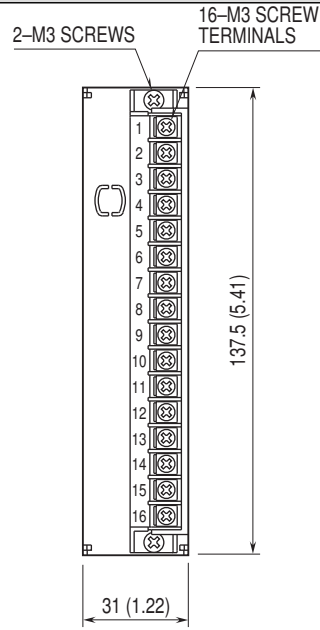
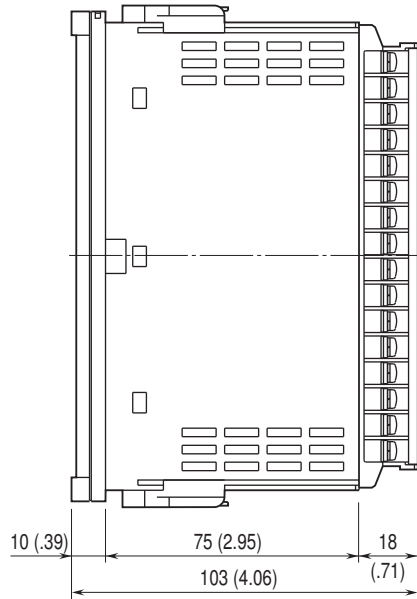
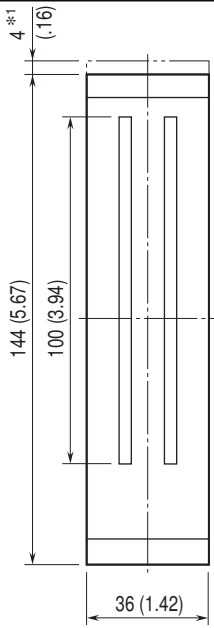

STANDARD BEZEL\*2

OPTION /D BEZEL\*3

OPTION /F BEZEL\*4

Rounded corners for the option /D

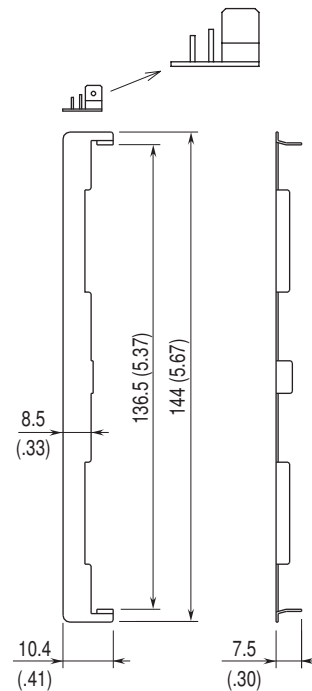
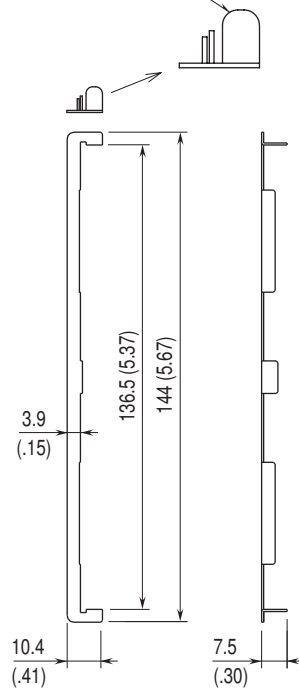
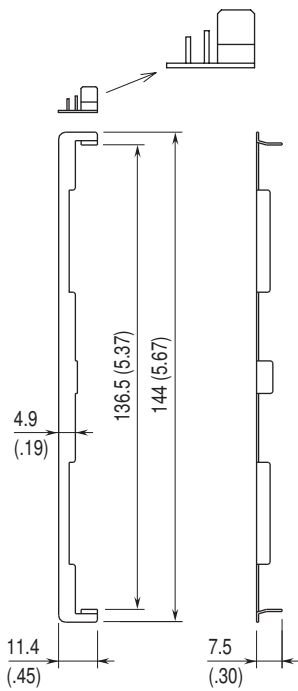

- \*1. Space required when replacing the scale plate.
- \*2. Used for the existing panel cutout of M-System 48 Series (38 × 139.5 mm).
- \*3. Used for the existing DIN panel cutout (33 × 138 mm)
- \*4. Used for the existing panel cutout of Fuji Electric PAJ, PAK, PBA (44 × 138 mm), etc.

## PANEL CUTOUT unit: mm

### ■ SINGLE MOUNTING (ingress protection)

#### • Vertical Mounting

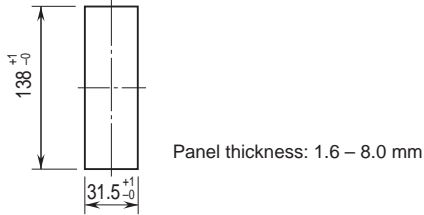

#### • Horizontal Mounting

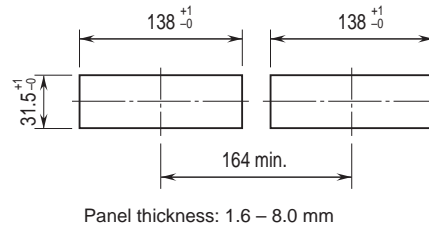

### ■ CLUSTERED MOUNTING (no ingress protection)

#### • Vertical Mounting

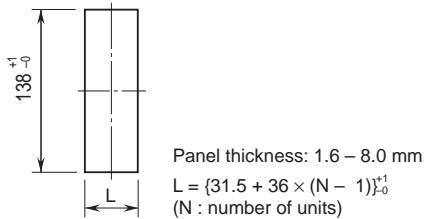

#### • Horizontal Mounting

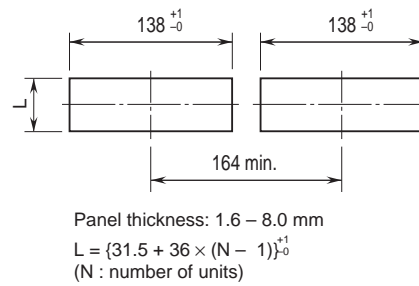

Note 1. Observe at the minimum of 3 cm above and below the units for heat dissipation.  
 Note 2. No bezel is needed when the panel is cut according to the above drawings.

## SCHEMATIC CIRCUITRY & CONNECTION DIAGRAM

48NV-1

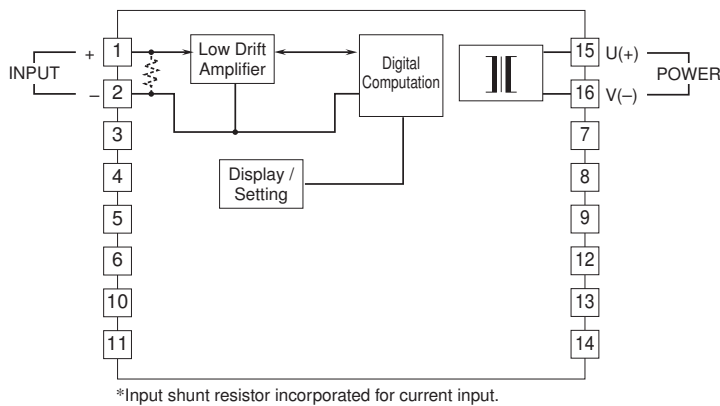

48NV-2

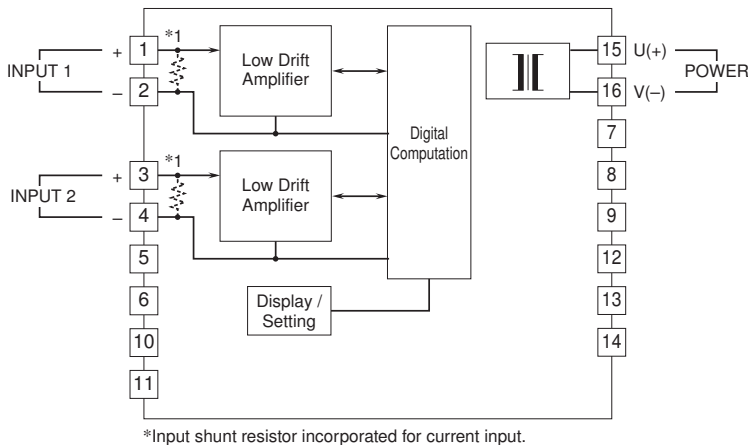



Specifications are subject to change without notice.