

SMART DIFFERENTIAL PRESSURE TRANSMITTER APR-2000ALW

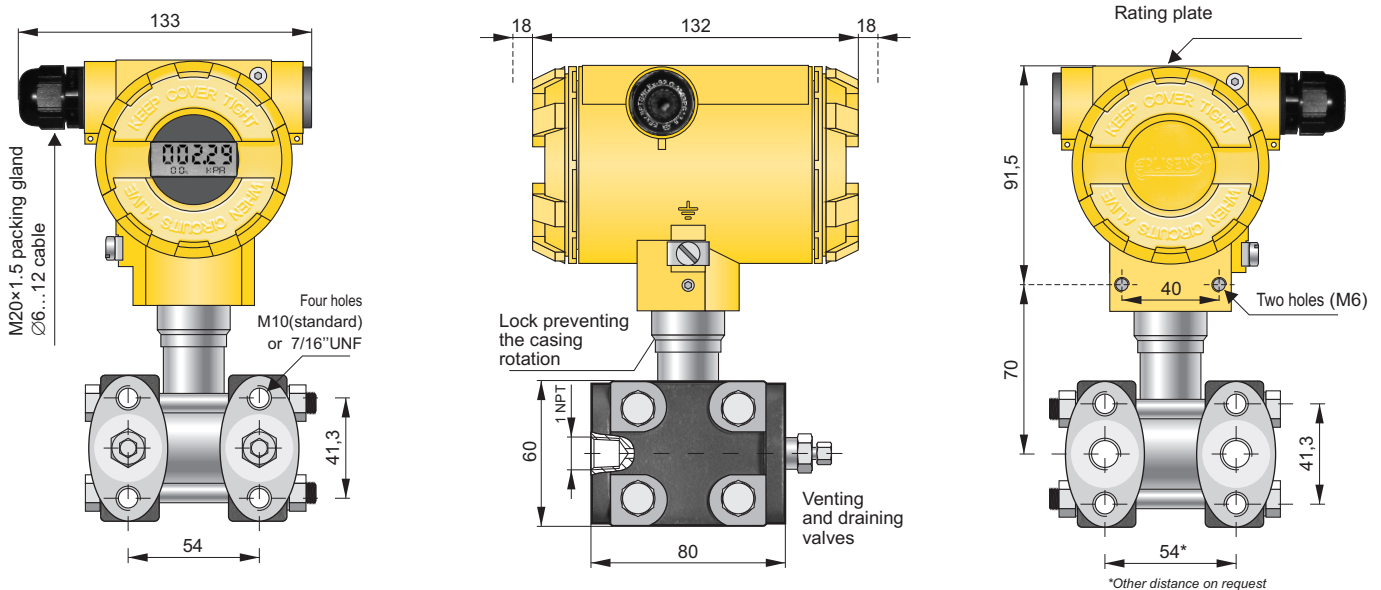

- ✓ Digital PROFIBUS PA signal
- ✓ 4...20 mA, 0...20 mA or 0...5 mA output signal + HART protocol
- ✓ ATEX Intrinsic safety
- ✓ ATEX Explosion proof
- ✓ PED Conformity (97/23/EC)
- ✓ Programmable zero range, shift, characteristic and damping ratio with local panel keys
- ✓ Static pressure limit up to 420 bar
- ✓ Accuracy 0.075% (better accuracy on request)
- ✓ SIL 2 certificate
- ✓ Marine certificate – DNV
- ✓ Gold plated diaphragms
- ✓ Wetted parts material Hastelloy C276 **NEW**



Transmitter **APR-2000ALW** – version with **type C** process connection to be mounted together with a valve manifold

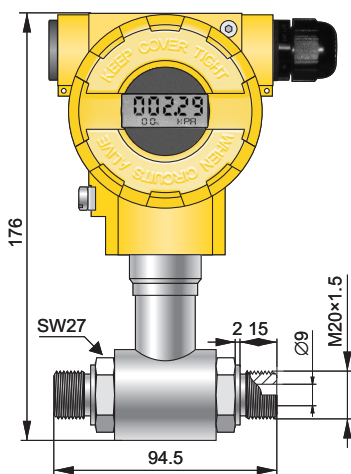

Transmitter **APR-2000ALW**
Version with **P** type process connection.

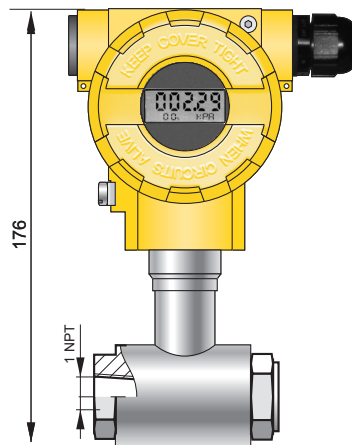

Transmitter **APR-2000ALW**
Version with **PN** type process connection.

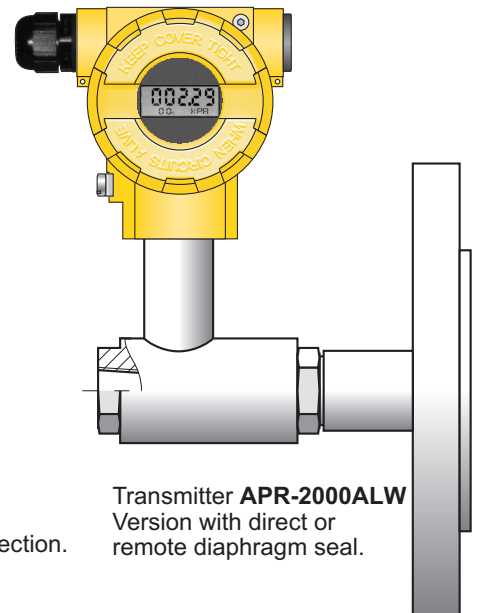

Transmitter **APR-2000ALW**
Version with direct or remote diaphragm seal.

Application and construction

The APR-2000ALW transmitter is applicable to the measurement of differential pressure of gases, vapours and liquids. The active element is a piezoresistant silicon sensor separated from the medium by separating diaphragms and a specially selected type of manometric fluid. The special design of the active sensing element ensures that it is able to withstand pressure surges and overloads of up to 250/320/420 bar. The casing is made of aluminium alloy cast or 316SS stainless steel, degree of protection IP66/IP67. The design of the casing enables the use of a local display, rotation of the display by 90°, rotation of the casing by 0–355° relative to the sensor, and a choice of cable direction.

Communication and configuration

The communication standard for data interchange with the transmitter is the Hart protocol.

Communication with the transmitter is carried out with:

- a KAP-03, KAP-03Ex communicator,
- some other Hart type communicators, (*)
- a PC using an HART/USB/Bluetooth converter and Raport 2 configuration software.

(*) .edd files available on www.aplisens.com

The data interchange with the transmitter enables the users to:

- ◆ identify the transmitter;
- ◆ configure the output parameters:
 - measurement units and the values of the start points and end points at the measurement range;
 - damping time constant;
 - conversion characteristic (inversion, user's non-linear characteristic);
- ◆ read the currently measured pressure value of the output current and the percentage output control level;
- ◆ force an output current with a set value;
- ◆ calibrate the transmitter in relation to a model pressure

Installation

The transmitter with **P** or **PN type** process connection is not heavy, so can be installed without additional mounting bracket on application. For fitting in any desired position we recommend an universal Aplisens mounting bracket for 2" pipe (AL mounting bracket, see page IV/ 5). The version with **C type** process connections can be fitted directly to a 3- or 5- valve manifold. We recommend factory-mounted transmitters with VM type valve manifold (page IV/ 2). A transmitter without a valve manifold can be fitted in any position on a 2" pipe or on a wall using the C-2" mounting bracket (page IV/ 5). When the special process connections are required for the measurement of specific media levels in closed tanks (e.g. in the sugar and chemical industries) the transmitter is fitted with an Aplisens diaphragm seal. Sets of differential pressure transmitters with diaphragm seals are described in detail in the further part of the catalogue.

Measuring ranges

No.	Nominal measuring range(FSO)*	Minimum set range	Rangeability	Overpressure limit/ static pressure limit
1	0...70 bar (0...7MPa)	7 bar (700kPa)	10:1	250 bar ,320bar, 420 bar (40 bar for P type Process connection) (250 bar for PED version)
2	0...16 bar (0...1,6MPa)	1,6 bar (160kPa)	10:1	
3	0...2,5 bar (0...250kPa)	0,2 bar (20kPa)	12,5:1	
4	0...1 bar (0...100kPa)	50mbar (5kPa)	20:1	
5	0...0,25 bar (0...25 kPa)	10mbar (1kPa)	25:1	
6	-0,5...0,5 bar (-50...50kPa)	0,1 bar (10kPa)	10:1	
7	-100...100mbar (-10...10kPa)	10mbar (1kPa)	20:1	
8	-5...70mbar (-0,5...7kPa)	4mbar (0,4kPa)	18:1	
9	-20...20 mbar (-2...2kPa)	2mbar (0,2kPa)	20:1	

*special nominal ranges on request

Technical data

Metrological parameters

Accuracy	≤ ±0.075% of calibrated range ≤ ±0.1% of calibrated range (range no. 9)
Long term stability (for the nominal measuring range)	≤ accuracy for 3 years
Thermal error	for ranges no 1-8 ≤ ±0.05% (FSO) / 10°C for ranges no 9 ≤ ±0.08% (FSO) / 10°C
max. ±0.3% (FSO) in temperature range	-25...80°C
special version for ranges no 1-8	≤ ±0.03% (FSO) / 10°C
max. ±0.1% (FSO) in temperature range	-25...80°C
Thermal compensation range	-25...80°C
Zero shift error for static pressure	
	0.01% (FSO) / 10 bar for range 3, 4, 5, 6
	0.03% (FSO) / 10 bar for range 1, 7, 8
	0.08% (FSO) / 10 bar for ranges 2, 7
Zeroing the transmitter in conditions of static pressure can eliminate this error.	
Additional electronic damping	0...60 s
Error due to supply voltage changes	0.002% (FSO) / V

Electrical parameters

Power supply:	
model APR-2000ALW	12...55 V DC (Ex ia 13,5...28 V) (Ex d 13,5...45V)
model APR-2000ALE	12...36 V DC
Additional voltage drop when display illumination switched on	3V
Output signal	4...20 mA, two wire transmission APR-2000ALE: 0...20 or 0...5, 4...20 [mA]
Loadresistance	$R[\Omega] \leq \frac{U_{sup}[V] - 12V^*}{0,02A} \cdot 0,85$
*-15V when display illumination switched on	
Resistance required for communication	250...1100 Ω

Materials

Wetted parts: type P, PN process connection: 316Lss
 type P(H) process connection: Hastelloy C276
 type C process connection 316ss

Diaphragms: 316Lss, Hastelloy C 276, Au

Casing: Aluminium
 Option: 316SS
 Material of window: polycarbonate glass, hardened glass

Operating conditions

Operating temperature range (ambient temp.) -25...85°C
 Exi version -25...80°C
 Exd version -25...75°C

Medium temperature range -25...120°C
 over 120°C – measurement with the use of impulse line or diaphragm seals
 up to 100°C PED version

CAUTION: the medium must not be allowed to freeze in the impulse line or close to the process connection of the transmitter

Accuracy depending on the set range

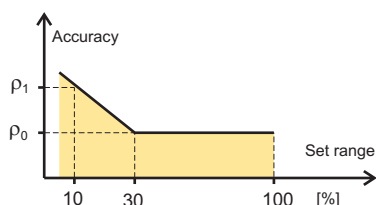

ρ_0 – error for nominal measuring range (0...100% FSO)
 ρ_1 – error for range 0...10% FSO
 $\rho_1 = 2 \times \rho_0$
 Numerical error values are given in the technical data under metrological parameters

SMART DIFFERENTIAL PRESSURE TRANSMITTER APR-2000AL/Profibus PA

Application and construction

The transmitter electronic system performs the digital processing of measurement and generates the output signal with the communication module according to Profibus PA standard. The transmitter function performance bases on profile 3.0 of Profibus PA standard.

The measuring ranges, according to the table, page II/ 3.

Communication

The communication with the transmitter is achieved in two ways:

- ♦ cyclic – the transmitter sends primary measured value (4 bytes IEEE754) and status containing the information on the current state of transmitter and measurement validity (1 byte).
- ♦ acyclic – this way of communication is used to device configuration and to read both primary measured value and the status

Configuration

Full configuration of transmitter settings, adjustment of the display mode, transmitter zeroing and calibration in relation to pressure standards proceeds with the PDM (Process Device Manager) software, by Siemens. The EED program library, worked out by Aplisens for cooperation with this transmitter, is helpful in the configuration.

Other commercial configuration software (e.g. Commuwin by Endress and Hauser, DTM/FDT tools) make transmitter configuration possible in the range of basic commands.

Enclosed to APR-2000AL/Profibus PA is GSD file comprising the description of the transmitter basic properties such as transmission rate, type and format of input data, list of additional functions. GSD file is necessary for the software serving as a device for network configuration and makes the correct

connection the appliance to Profibus network possible. The universal file GSD, designed for standard pressure transmitters made according to profile at revision 3 Profibus standard, may also be applicable to APR-2000AL/Profibus PA. The pressure transmitter APR-2000AL/Profibus PA does not have the hardware address switch This address may be adjusted with accessible configuration software.

Measurements in the areas under explosion hazard

For pressure measurements in the areas under explosion hazard the ATEX intrinsically safe transmitters, $\text{Ex} \text{ II } 1/2\text{G Exia IIB T5}$ are available

Technical data

Metrological parameters, measuring range, materials of process connection, diaphragms and casing, and operating conditions – see the description pages II/ 3, II/ 4.

Electrical parameters

Power supply (from DP/PA coupler)
 10,5 \pm 28V DC
 12.05 \pm 28V DC - when display illumination switched on. Power supply from intrinsically safe coupler according to FISCO requirements.
 $V_i = 15\text{VDC}$
 $I_i = 0,38\text{A}$ for IIB
 Current consumption 14mA

Output parameters

Output signal Digital communication signal Profibus – PA (according to EN 50170)

PA function slave

Physical layer IEC61158-2

Transmission range 31,25kBit/S

Modulation Manchester II

Electrical diagrams

Electrical diagrams for transmitters with HART protocol

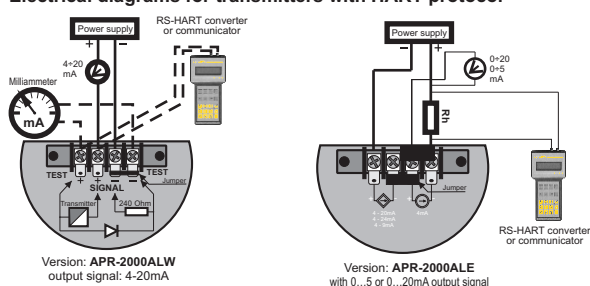

Transmitters with Profibus PA

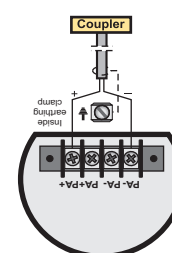

Ordering procedure

Model	Code	Description	
APR-2000		Smart differential pressure transmitter.	
Casing, Output signal, ⇒	ALW.....	Aluminum housing, IP66/IP67, with display, output 4-20mA + Hart	
	ALE.....	Special version 0 - 20mA+ Hart, 0 - 5mA+ Hart,	
	AL./Profibus PA.....	Aluminium housing, IP66, without display, output Profibus PA	
	AL./Profibus PA/W.....	Aluminium housing, IP66/IP67, with display, output Profibus PA	
	ALW/SS.....	Stainless steel housing, IP66/IP67, with display, output 4-20mA + Hart	
Versions, Certificates* *) more than one option is available	/EEx ia.....	Ex II 1/2G Exia IIC T4/T5 Ga/Gb, II 1 D Exia IIIC T105C Da I M1 Ex ia I Ma (only version with SS housing) (not available for ALE) for Profibus PA version Ex II 1/2G EExia IIB T5	
	/EEx xd.....	Ex II 1/2G Exia/d IIC T5/T6 Ga/Gb Ex II 1/2D Exia/ft IIIC T85/T100 Da/Db, for pressure >250mbar (not available for ALE AL/Profibus PA, AL./Profibus PA/W,).Packing gland available on request.	
	/PED.....	European Pressure Equipment Directive N° 97/23/EC, category IV	
	/Tlen.....	For oxygen service (sensor filled with Fluorolube fluid)	
	/320bar.....	Static pressure 320bar /only for C process connection, standard is 250bar/, option not available in PED version.	
	/420bar.....	Static pressure 420bar /option not available in PED version/.	
Nominal measuring range	/0÷70bar.....	0÷70bar (0÷7000kPa)	7bar (700kPa)
	/0÷16bar.....	0÷16bar (0÷1600kPa)	1,6bar (160kPa)
	/0÷2,5bar.....	0÷2,5bar (0÷250kPa)	0,2bar (20kPa)
	/0÷1bar.....	0÷1bar (0÷100kPa)	50mbar (5kPa)
	/0÷0,25bar.....	0÷0,25bar (0÷25kPa)	10mbar (1kPa)
	/-0,5÷ +0,5bar.....	-0,5÷+0,5bar (-50÷50kPa)	0.1bar (10kPa)
	/-0,1÷ +0,1bar.....	-0,1÷+0,1bar (-10÷10kPa)	10mbar (1kPa)
	/-5÷70mbar.....	-5÷70mbar (-0.5÷7kPa)	4mbar (0.4kPa)
	/0÷70bar.....	0÷70bar (0÷7MPa)	7bar (700kPa)
	/-20÷20mbar.....	-20÷20mbar (-2 ÷2 kPa)	2 mbar (0.2 kPa)
Measuring set range	/...⇒. [required units]	Calibrated range in relation to 4mA and 20mA output	
Process connections ⇒	/C.....	Thread 1/4NPT F on the cover flanges, diaphragms material 316Lss, cover flanges material SS316. Allows mounting with a valve manifold. Process connection of cover flange: M10(standard)/ 7/16UNF(option)-C(7/16)	
	/C(H).....	Thread 1/4NPT F on the cover flanges, diaphragms material Hastelloy C276, cover flanges material SS316. Allows mounting with a valve manifold.	
	/C(Au).....	Thread 1/4NPT F on the cover flanges, gold plated diaphragm, cover flanges material SS316 . Available with range no.4 Allows mounting with a valve manifold. Process connection of cover flange: M10(standard)/ 7/16UNF(option)-C(H,7/16)	
	/P.....	Thread M20x1,5 (male), wetted parts material SS316L	
	/PN.....	Thread 1/4"NPT (female), wetted parts material SS316L	
	/P.(H).....	Thread M20x1,5 (male), wetted parts material Hastelloy C276	
	/code of diaphragm seal.....	Diaphragm seal (see chapter of diaphragm seals) mounted on Hi side of transmitter, Lo side 1/4NPT Female	
Gasket (only in C process connection) ⇒	(without marking).....	FPM Viton,	
	NBR.....	NBR (for oxygen service)	
Electrical connection ⇒	(without marking).....	Packing gland M20x1,5	
	/US.....	Thread 1/2NPT Female	
Accessories ** **) more than one option is available	/C-2".....	Mounting bracket for 2" pipe (to C process conn.), mat. zincd steel	
	/C-2"(SS).....	Mounting bracket for 2" pipe (to C process conn.), mat. Stainless Steel	
	/FI25.....	Mounting bracket for 2" pipe (to P process conn.), mat. stainless steel	
	/RedSpaw P.....	Connector to weld impulse pipes dia. 12 and 14 mm , material 15HM(SO) or SS 316(S) . Only process connection P type,	
	/RedSpaw C.....	Connector to weld impulse pipes dia. 12 and 14 mm, material 15HM. Only process connection C type.	
	/Red d/P. ½".....	Adapter for differential pressure transmitters with C type process connection, output thre ad 1/2NPT F. Material 316 LSS	
	/ST.....	Stainless Steel plate riveted to the housing	
	/MT.....	Stainless Steel Tag plate mounted on wire	
Other specification	/.....	Description of required parameters	

The most typical specification is marked by "⇒" mark.