

Remote I/O R7K4FML Series

MECHATROLINK I/O MODULE

(MECHATROLINK-I/-II)

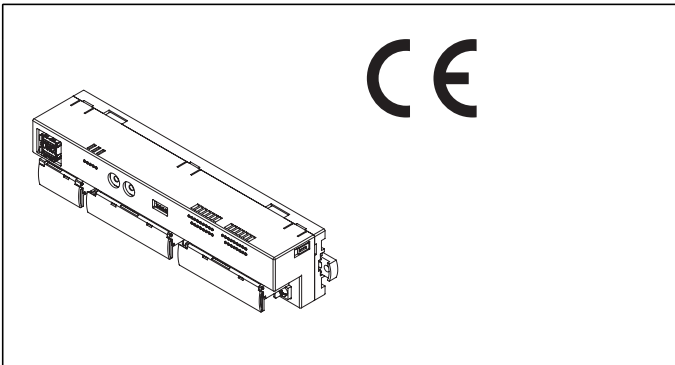

MODEL: R7K4FML-6-[1]-R

ORDERING INFORMATION

- Code number: R7K4FML-6-[1]-R
Specify a code from below for [1].
(e.g. R7K4FML-6-DCA32A-R)

TERMINAL BLOCK

- 6: Screw terminal block for power supply
Connector for MECHATROLINK- II
Screw terminal block for I/O

[1] I/O TYPE

- DA32:** NPN/PNP discrete input, 32 points
- DCA32A:** NPN transistor output & NPN/PNP discrete input, 16 points each

POWER INPUT

- DC power**
R: 24 V DC
(Operational voltage range: $\pm 10\%$; ripple 10 %p-p max.)

FUNCTIONS & FEATURES

R7K4FML, complying with MECHATROLINK-I/-II and Simple I/O, interfaces discrete I/Os and PLC or PC via MECHATROLINK.
Removable terminal blocks make the module replaceable without disconnection of wiring.

GENERAL SPECIFICATIONS

- Common Specifications
Power input: 24 V DC $\pm 10\%$
Insulation resistance: $\geq 100\text{ M}\Omega$ with 500 V DC
Operating temperature: 0 to 55°C (32 to 131°F)

Operating humidity: 30 to 90 %RH (non-condensing)

Atmosphere: No corrosive gas or heavy dust

Storage temperature: -20 to +65°C (-4 to +149°F)

Mounting: DIN rail (35 mm wide) or wall

Connection

Communication: MECHATROLINK connector

Power & I/O: M3 screw terminals (torque 0.5 N·m)
2 pieces mounting

Screw terminal material: Nickel-plated steel

Recommended solderless terminal:

Applicable wire size: 0.25 to 1.65 mm² (AWG 22 to 16)

Recommended manufacturer: Japan Solderless Terminal MFG.Co.Ltd, Nichifu Co.,Ltd

Status indicator LEDs: PWR, ERR, SD, RD (Refer to the instruction manual for details)

■ Current Consumption & Weight

R7K4FML-6-DA32: 55 mA, 330 g (0.73 lb)

R7K4FML-6-DCA32A: 60 mA, 330 g (0.73 lb)

(Discrete I/O load charge is not included in the above-mentioned current consumption.)

■ Recommended solderless terminal

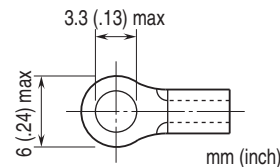

MECHATROLINK COMMUNICATION

■ MECHATROLINK:

Mode: Set with DIP switches
(MECHATROLINK-I or -II, data length; Factory setting: MECHATROLINK-II; data length (32 byte)
(Refer to the manual)

Station address: 60H - 7FH
(Function selected with Rotary SW. Factory setting: 61H).
(Refer to the manual)

• MECHATROLINK-I

Baud rate: 4 Mbps

Transmission distance: 50 m max.

Distance between stations: 30 cm min.

Transmission media: MECHATROLINK cable (Model JEPMC-W6003-x-E, Yaskawa Controls Co., Ltd.)

Max. number of slaves: 15

(The maximum number of slaves might change depending on the master unit. Refer to the manual of the master unit)

Transmission cycle: 2 msec. (fixed)

Data length: 17 byte

• MECHATROLINK-II

Baud rate: 10 Mbps

Transmission distance: 50 m max.

Distance between stations: 50 cm min.

Transmission media: MECHATROLINK cable (Model JEPMC-W6003-x-E, Yaskawa Controls Co., Ltd.)

Max. number of slaves: 30

(The maximum number of slaves might change depending on the master unit. Refer to the manual of the master unit)

Transmission cycle: 0.25 msec., 0.5 msec., 1 msec., 1.5 msec., 2 msec., 4 msec., 8 msec.

Data length: 17 bytes / 32 bytes selectable (Must choose identical data size for all stations on one network)

STANDARDS & APPROVALS

CE conformity:

EMC Directive (2004/108/EC)

EMI EN 61000-6-4: 2007

EMS EN 61000-6-2: 2005

EXTERNAL VIEW

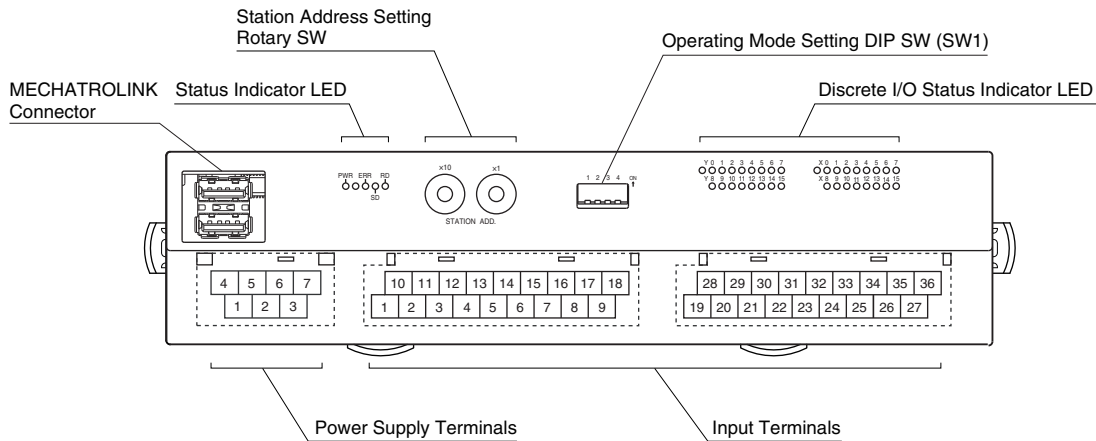

CONNECTION DIAGRAMS

■ POWER SUPPLY TERMINAL ASSIGNMENT

4	5	6	7
NC	NC	+24V	0V
1	2	3	
NC	NC	FE	

1. NC	-
2. NC	-
3. FE	FE
4. NC	-
5. NC	-
6. +24V	Power supply (24V DC)
7. 0V	Power supply (0V)

■ MECHATROLINK CONNECTION

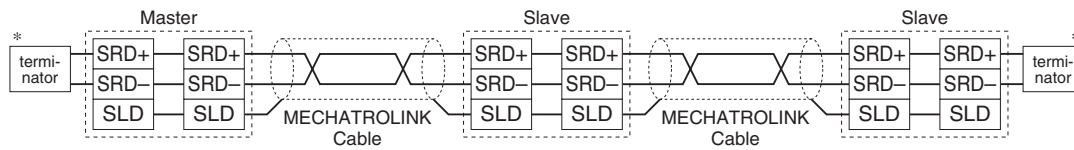

*Terminator

Be sure to connect the terminating resistors to the unit at both ends of transmission line.

Use the terminating resistor dedicated for MECHATROLINK: Model JEPMC-W6022, Yaskawa Controls Co., Ltd.

Certain types of Master units may have incorporated terminating resistors. Consult the instruction manual for the Master.

MECHATROLINK RELATED COMMANDS

R7K4FML (Simple I/O) communicates with I/O service with no processor, therefore it uses a connectionless communication protocol. There is no application layer either; the R7K4FML interchanges I/O data by a data link layer.

■ MECHATROLINK DATA LINK LAYER COMMAND DESCRIPTIONS

The following tables explain Commands supported by the R7K4FML.

• MDS Command (04H) Data Format

BYTE	COMMAND	RESPONSE	REMARKS
0	MDS (04H)	S(0) (90H)	Message Data Search (MDS) Command: Read the ID from the slave station S(0): Response to MDS
1	0	ID	
2	0		
3	0	0	All 0
4	0	0	
5	0	0	
6	0	0	
7	0	0	
8	0	0	
9	0	0	
10	0	0	
11	0	0	
12	0	0	
13	0	0	
14	0	0	
15	0	0	
16	0	0	
17	0	0	Byte 17 through 31 are always 0 in the 32-byte mode. These bytes are unavailable for MECHATROLINK-I, or MECHATROLINK-II in the 17-byte mode.
:	:	:	
31	0	0	

• CDRW Command (03H) Data Format

BYTE	COMMAND	RESPONSE	REMARKS
0	CDRW (03H)	ACK (01H)	Cyclic Data Read/Write (CDRW) Command: Link transmission Acknowledge (ACK): Positive response to CDRW
1	Out Data: Lowest	In Data: Lowest	Data ordinance: Little Endian
2			
3			
4			
5			
6			
7			
8			
9			
10			
11			
12			
13			
14			
15			
16			
17	(Out Data: Highest)	(In Data: Highest)	These bytes are unavailable for MECHATROLINK-I, or MECHATROLINK-II in the 17-byte mode.
:			
31			

I/O DATA DESCRIPTIONS

■ DISCRETE I/O

●In 0 to 31. Out 0 to 32: 0: OFF, 1: ON

●17-BYTE MODE

●16 points output, Out Data

Byte	Bit7	Bit6	Bit5	Bit4	Bit3	Bit2	Bit1	Bit0
1	0	0	0	0	0	0	0	0
2	0	0	0	0	0	0	0	0
3	0	0	0	0	0	0	0	0
4	0	0	0	0	0	0	0	0
5	0	0	0	0	0	0	0	0
⋮	0	0	0	0	0	0	0	0
12	0	0	0	0	0	0	0	0
13	0	0	0	0	0	0	0	0
14	0	0	0	0	0	0	0	0
15	Out7	Out6	Out5	Out4	Out3	Out2	Out1	Out0
16	Out15	Out14	Out13	Out12	Out11	Out10	Out9	Out8

●32 points output, Out Data

Byte	Bit7	Bit6	Bit5	Bit4	Bit3	Bit2	Bit1	Bit0
1	0	0	0	0	0	0	0	0
2	0	0	0	0	0	0	0	0
3	0	0	0	0	0	0	0	0
4	0	0	0	0	0	0	0	0
5	0	0	0	0	0	0	0	0
⋮	0	0	0	0	0	0	0	0
12	0	0	0	0	0	0	0	0
13	Out7	Out6	Out5	Out4	Out3	Out2	Out1	Out0
14	Out15	Out14	Out13	Out12	Out11	Out10	Out9	Out8
15	Out23	Out22	Out21	Out20	Out19	Out18	Out17	Out16
16	Out31	Out30	Out29	Out28	Out27	Out26	Out25	Out24

●32-BYTE MODE

●16 points output, Out Data

Byte	Bit7	Bit6	Bit5	Bit4	Bit3	Bit2	Bit1	Bit0
1	0	0	0	0	0	0	0	0
2	0	0	0	0	0	0	0	0
3	0	0	0	0	0	0	0	0
4	0	0	0	0	0	0	0	0
5	0	0	0	0	0	0	0	0
⋮	0	0	0	0	0	0	0	0
28	0	0	0	0	0	0	0	0
29	0	0	0	0	0	0	0	0
30	0	0	0	0	0	0	0	0
31	Out7	Out6	Out5	Out4	Out3	Out2	Out1	Out0
32	Out15	Out14	Out13	Out12	Out11	Out10	Out9	Out8

●32 points output, Out Data

Byte	Bit7	Bit6	Bit5	Bit4	Bit3	Bit2	Bit1	Bit0
1	0	0	0	0	0	0	0	0
2	0	0	0	0	0	0	0	0
3	0	0	0	0	0	0	0	0
4	0	0	0	0	0	0	0	0
5	0	0	0	0	0	0	0	0
⋮	0	0	0	0	0	0	0	0
28	0	0	0	0	0	0	0	0
29	Out7	Out6	Out5	Out4	Out3	Out2	Out1	Out0
30	Out15	Out14	Out13	Out12	Out11	Out10	Out9	Out8
31	Out23	Out22	Out21	Out20	Out19	Out18	Out17	Out16
32	Out31	Out30	Out29	Out28	Out27	Out26	Out25	Out24

●16 points input, In Data

Byte	Bit7	Bit6	Bit5	Bit4	Bit3	Bit2	Bit1	Bit0
1	In7	In6	In5	In4	In3	In2	In1	In0
2	In15	In14	In13	In12	In11	In10	In9	In8
3	0	0	0	0	0	0	0	0
4	0	0	0	0	0	0	0	0
5	0	0	0	0	0	0	0	0
⋮	0	0	0	0	0	0	0	0
12	0	0	0	0	0	0	0	0
13	0	0	0	0	0	0	0	0
14	0	0	0	0	0	0	0	0
15	0	0	0	0	0	0	0	0
16	0	0	0	0	0	0	0	0

●32 points input, In Data

Byte	Bit7	Bit6	Bit5	Bit4	Bit3	Bit2	Bit1	Bit0
1	In7	In6	In5	In4	In3	In2	In1	In0
2	In15	In14	In13	In12	In11	In10	In9	In8
3	In23	In22	In21	In20	In19	In18	In17	In16
4	In31	In30	In29	In28	In27	In26	In25	In24
5	0	0	0	0	0	0	0	0
⋮	0	0	0	0	0	0	0	0
12	0	0	0	0	0	0	0	0
13	0	0	0	0	0	0	0	0
14	0	0	0	0	0	0	0	0
15	0	0	0	0	0	0	0	0
16	0	0	0	0	0	0	0	0

●16 points input, In Data

Byte	Bit7	Bit6	Bit5	Bit4	Bit3	Bit2	Bit1	Bit0
1	In7	In6	In5	In4	In3	In2	In1	In0
2	In15	In14	In13	In12	In11	In10	In9	In8
3	0	0	0	0	0	0	0	0
4	0	0	0	0	0	0	0	0
5	0	0	0	0	0	0	0	0
⋮	0	0	0	0	0	0	0	0
28	0	0	0	0	0	0	0	0
29	0	0	0	0	0	0	0	0
30	0	0	0	0	0	0	0	0
31	0	0	0	0	0	0	0	0
32	0	0	0	0	0	0	0	0

●32 points input, In Data

Byte	Bit7	Bit6	Bit5	Bit4	Bit3	Bit2	Bit1	Bit0
1	In7	In6	In5	In4	In3	In2	In1	In0
2	In15	In14	In13	In12	In11	In10	In9	In8
3	In23	In22	In21	In20	In19	In18	In17	In16
4	In31	In30	In29	In28	In27	In26	In25	In24
5	0	0	0	0	0	0	0	0
⋮	0	0	0	0	0	0	0	0
28	0	0	0	0	0	0	0	0
29	0	0	0	0	0	0	0	0
30	0	0	0	0	0	0	0	0
31	0	0	0	0	0	0	0	0
32	0	0	0	0	0	0	0	0

DIMENSIONS unit: mm (inch)

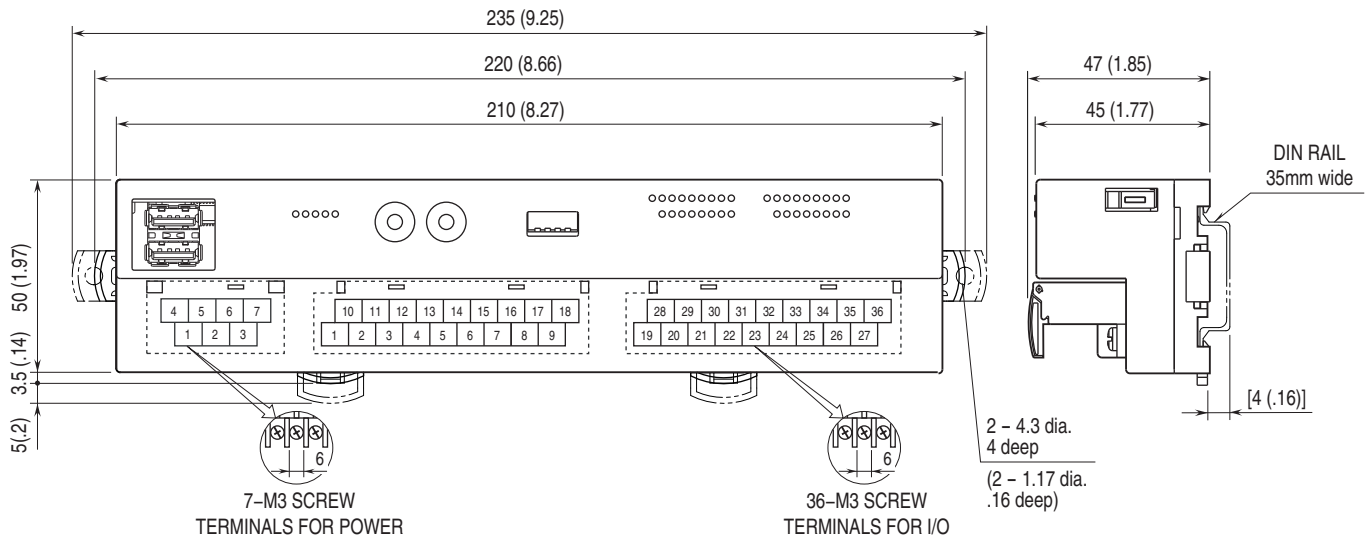

DISCRETE INPUT MODULE

(32 points, screw terminal type, MECHATROLINK-I/II use)

MODEL: R7K4FML-6-DA32

SPECIFICATIONS

Common: Positive or negative common (NPN/PNP) per 32 points

Number of I/O: Input, 32 points

Maximum inputs applicable at once: No limit (at 24 V DC)

Input status indicator: Green LED turns ON with contact ON

Isolation: Input to MECHATROLINK or FE to power input

Rated input voltage: 24 V DC $\pm 10\%$; ripple 5 %p-p max.

ON voltage / current: ≥ 15 V DC (input - COM) / ≥ 3.5 mA

OFF voltage / current: ≤ 5 V DC (input - COM) / ≤ 1 mA

Input current: ≤ 5.5 mA per point at 24 V DC

Input resistance: Approx. 4.4 k Ω

ON delay: ≤ 0.5 msec.

OFF delay: ≤ 1.0 msec.

Dielectric strength: 1500 V AC @ 1 minute (input to power)

500 V AC @ 1 minute (MECHATROLINK or FE to input or power)

OPERATING MODE SETTING

(*) Factory setting

Caution ! - SW1-3 and SW1-4 are unused. Be sure to turn off unused ones.

MECHATROLINK MODE

Choose MECHATROLINK-I or -II, and the data size.

SW1-1 and SW1-2 are used.

SW1-1	SW1-2	MECHATROLINK
OFF	OFF	MECHATROLINK-II (32 byte mode) (*)
ON	OFF	MECHATROLINK-II (17 byte mode)
OFF	ON	Unused
ON	ON	MECHATROLINK-I (17 byte mode)

TERMINAL ASSIGNMENTS

10	11	12	13	14	15	16	17	18
COM	X1	X3	X5	X7	X9	X11	X13	X15
1	2	3	4	5	6	7	8	9
COM	X0	X2	X4	X6	X8	X10	X12	X14

28	29	30	31	32	33	34	35	36
COM	X17	X19	X21	X23	X25	X27	X29	X31
19	20	21	22	23	24	25	26	27
COM	X16	X18	X20	X22	X24	X26	X28	X30

NO.	ID	FUNCTION	NO.	ID	FUNCTION
1	COM	Common	10	COM	Common
2	X0	Input 0	11	X1	Input 1
3	X2	Input 2	12	X3	Input 3
4	X4	Input 4	13	X5	Input 5
5	X6	Input 6	14	X7	Input 7
6	X8	Input 8	15	X9	Input 9
7	X10	Input 10	16	X11	Input 11
8	X12	Input 12	17	X13	Input 13
9	X14	Input 14	18	X15	Input 15

NO.	ID	FUNCTION	NO.	ID	FUNCTION
19	COM	Common	28	COM	Common
20	X16	Input 16	29	X17	Input 17
21	X18	Input 18	30	X19	Input 19
22	X20	Input 20	31	X21	Input 21
23	X22	Input 22	32	X23	Input 23
24	X24	Input 24	33	X25	Input 25
25	X26	Input 26	34	X27	Input 27
26	X28	Input 28	35	X29	Input 29
27	X30	Input 30	36	X31	Input 31

SCHEMATIC CIRCUITRY & CONNECTION DIAGRAM

Note: In order to improve EMC performance, bond the FE terminal to ground.

Caution: FE terminal is NOT a protective conductor terminal.

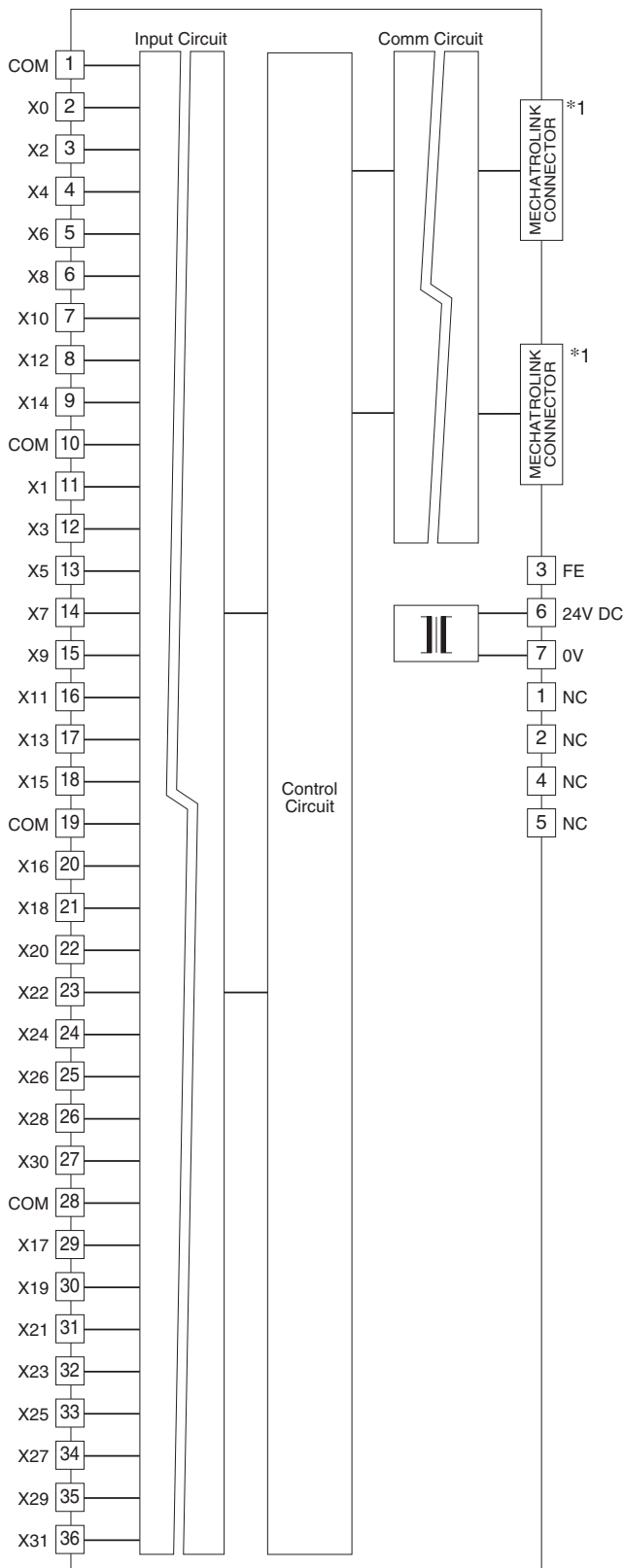

*MECHATROLINK connectors are internally connected.
The network cable can be connected to either one.

Input Circuit

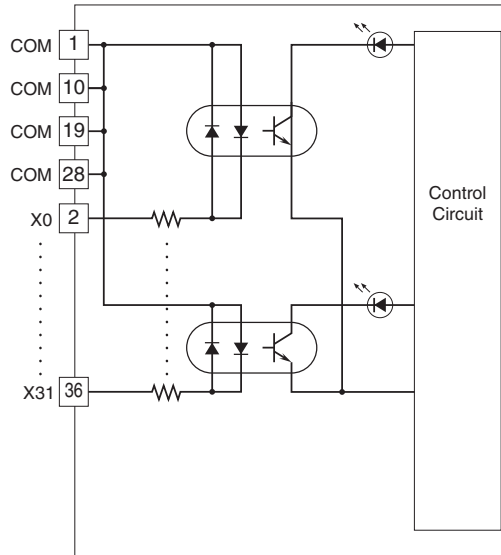

Input Connection Examples

PNP Connection

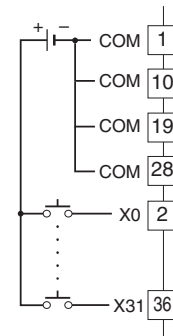

NPN Connection

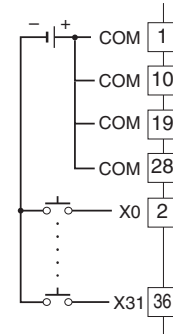

NPN TRANSISTOR OUTPUT & DISCRETE INPUT MODULE

(16 points each, screw terminal type, MECHATROLINK-I/II use)

MODEL: R7K4FML-6-DCA32A

SPECIFICATIONS

COMMON SPECIFICATIONS

Input common: Positive or negative (NPN/PNP) per 16 points

Output common: Negative common (NPN) per 16 points

Number of I/O: Input, 16 points; Output, 16 points

Maximum I/O applicable at once: No limit (at 24 V DC)

I/O status indicator: Green LED turns ON with contact ON

Isolation: Input to output to MECHATROLINK or FE to power input

INPUT

Rated input voltage: 24 V DC $\pm 10\%$; ripple 5 %p-p max.

ON voltage / current: ≥ 15 V DC (input - GND) / ≥ 3.5 mA

OFF voltage / current: ≤ 5 V DC (input - GND) / ≤ 1 mA

Input current: ≤ 5.5 mA per point at 24 V DC

Input resistance: Approx. 4.4 k Ω

ON delay: ≤ 0.5 msec.

OFF delay: ≤ 1.0 msec.

OUTPUT

Rated load voltage: 24 V AC $\pm 10\%$ (ripple 5 %p-p max.)

Rated output current: 0.1 A per point, 1.6 A per common

Residual voltage: ≤ 1.2 V

Leakage current: ≤ 0.1 mA

ON delay: ≤ 0.5 msec.

OFF delay: ≤ 1.0 msec.

Overload current protection function: Limits the current value when overcurrent is detected

Overheat Protection Function:

Turns OFF the output when overheat is detected

Dielectric strength: 1500 V AC @ 1 minute (input to output to power)

500 V AC @ 1 minute (MECHATROLINK or FE to input or output to power)

OPERATING MODE SETTING

(*) Factory setting

Caution ! - SW1-3 and SW1-4 are unused. Be sure to turn off unused ones.

MECHATROLINK MODE

Choose MECHATROLINK-I or -II, and the data size.

SW1-1 and SW1-2 are used.

SW1-1	SW1-2	MECHATROLINK
OFF	OFF	MECHATROLINK-II (32 byte mode) (*)
ON	OFF	MECHATROLINK-II (17 byte mode)
OFF	ON	Unused
ON	ON	MECHATROLINK-I (17 byte mode)

TERMINAL ASSIGNMENTS

10	11	12	13	14	15	16	17	18
+24V	Y1	Y3	Y5	Y7	Y9	Y11	Y13	Y15
1	2	3	4	5	6	7	8	9
0V	Y0	Y2	Y4	Y6	Y8	Y10	Y12	Y14

28	29	30	31	32	33	34	35	36
COM	X1	X3	X5	X7	X9	X11	X13	X15
19	20	21	22	23	24	25	26	27
COM	X0	X2	X4	X6	X8	X10	X12	X14

NO.	ID	FUNCTION	NO.	ID	FUNCTION
1	0V	0V (Out Common)	10	+24V	24V DC
2	Y0	Output 0	11	Y1	Output 1
3	Y2	Output 2	12	Y3	Output 3
4	Y4	Output 4	13	Y5	Output 5
5	Y6	Output 6	14	Y7	Output 7
6	Y8	Output 8	15	Y9	Output 9
7	Y10	Output 10	16	Y11	Output 11
8	Y12	Output 12	17	Y13	Output 13
9	Y14	Output 14	18	Y15	Output 15

NO.	ID	FUNCTION	NO.	ID	FUNCTION
19	COM	Common	28	COM	Common
20	X0	Input 0	29	X1	Input 1
21	X2	Input 2	30	X3	Input 3
22	X4	Input 4	31	X5	Input 5
23	X6	Input 6	32	X7	Input 7
24	X8	Input 8	33	X9	Input 9
25	X10	Input 10	34	X11	Input 11
26	X12	Input 12	35	X13	Input 13
27	X14	Input 14	36	X15	Input 15

SCHEMATIC CIRCUITRY & CONNECTION DIAGRAM

Note: In order to improve EMC performance, bond the FE terminal to ground.

Caution: FE terminal is NOT a protective conductor terminal.

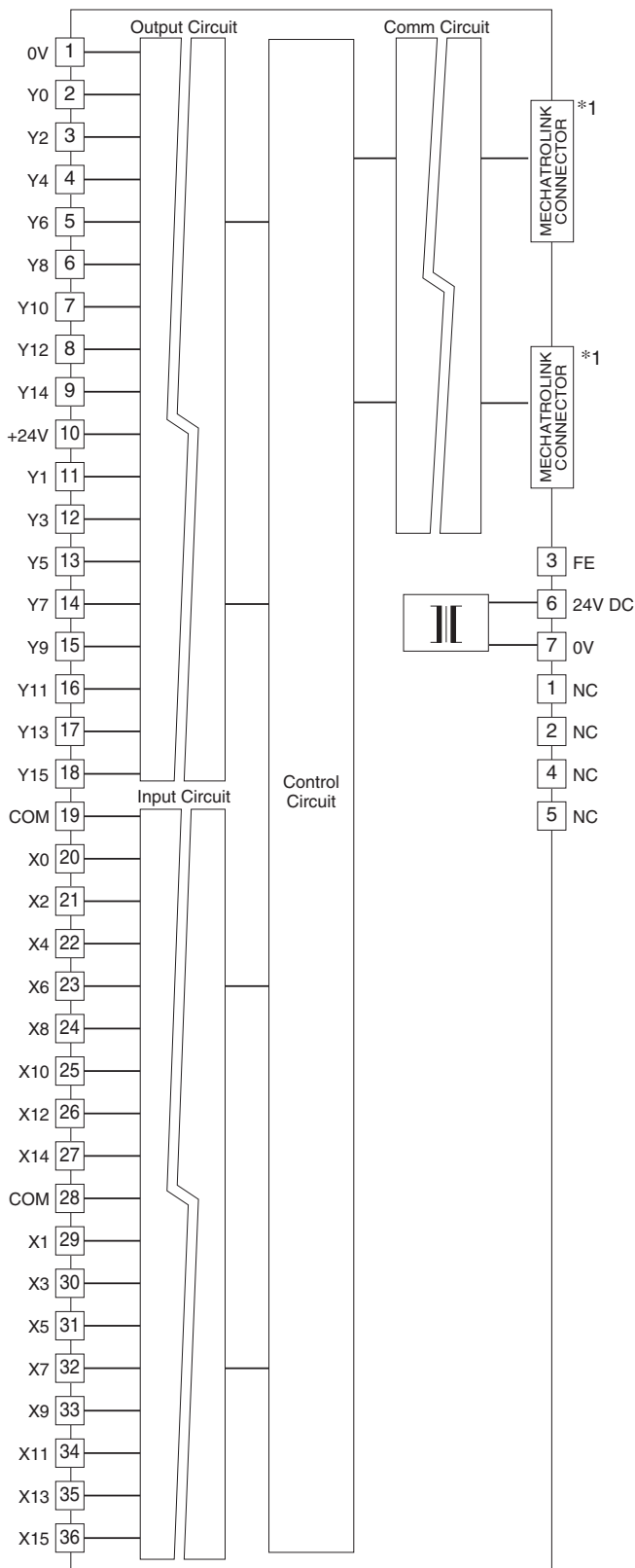

*MECHATROLINK connectors are internally connected.
The network cable can be connected to either one.

Output Circuit

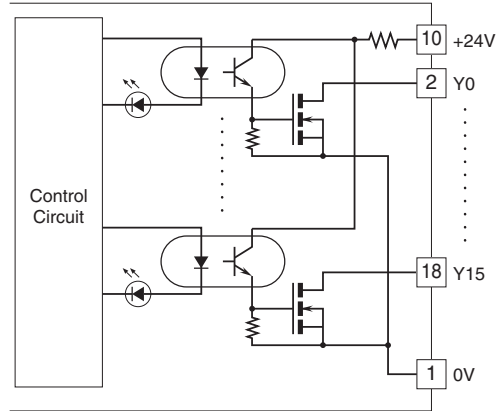

Output Connection Examples

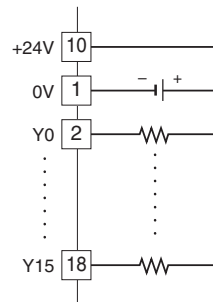

Input Circuit

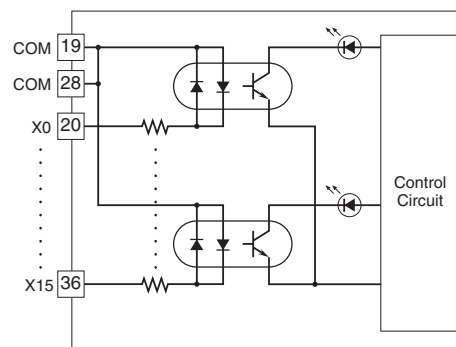

Input Connection Examples

PNP Connection

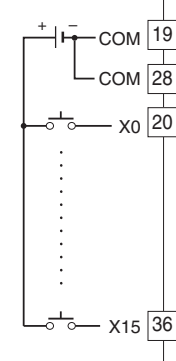

NPN Connection

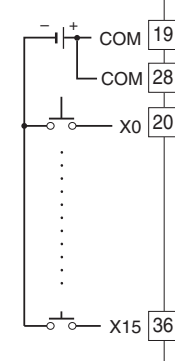



Specifications are subject to change without notice.